

**REGULAR MEETING – November 12, 2024**

On this the 12<sup>th</sup> day of November 2024 at 9:00 A.M. the Honorable Commissioners Court of Blanco County convened in a REGULAR MEETING at a special meeting place thereof in the Courthouse Annex, Hoppe Room, in Johnson City with the following members to-wit:

BRETT BRAY	COUNTY JUDGE
TOMMY WEIR	COMMISSIONER PCT. 1
EMIL UECKER	COMMISSIONER PCT. 2
CHRIS LIESMANN	COMMISSIONER PCT. 3
CHARLES RILEY	COMMISSIONER PCT. 4

---

**Call to order and roll call.**

The Judge and all Commissioners marked present.

**Pledge of Allegiance(s) – United States and Texas**

**Invocation** – Led by Christina Harris.

**PUBLIC COMMENTS** – opportunity for the general public to address the Court on any agenda item. Comments are limited to 3 minutes.

KENNETH WELCH – AGENDA ITEM 6

**ITEM 1** – Consider approval of minutes of prior Commissioners Court meeting(s). Vote on any action taken. (Judge Bray)

COMMISSIONER UECKER made the motion to dispense with the reading of the minutes and to approve the minutes as presented, seconded by Commissioner Riley. Judge Bray called for discussion and vote.

JUDGE BRAY – YES.

COMMISSIONER WEIR – YES.

COMMISSIONER UECKER – YES.

COMMISSIONER LIESMANN – YES.

COMMISSIONER RILEY – YES. MOTION CARRIED. 5/0

**ITEM 2** – Consider approval of the estimated November 2024 payroll. Vote on any action taken. (Judge Bray)

COMMISSIONER LIESMANN made the motion to approve the estimated payroll in the amount of \$588,114.14, seconded by Commissioner Uecker. Judge Bray called for discussion and vote.

JUDGE BRAY – YES.  
COMMISSIONER WEIR – YES.  
COMMISSIONER UECKER – YES.  
COMMISSIONER LIESMANN – YES.  
COMMISSIONER RILEY – YES. MOTION CARRIED. 5/0

**ITEM 3** – Consider approval of the official reports for October 2024. Vote on any action taken. (Judge Bray)

COMMISSIONER WEIR moves that we approve the official reports for October 2024, seconded by Commissioner Riley. Judge Bray called for discussion and vote.

JUDGE BRAY – YES.  
COMMISSIONER WEIR – YES.  
COMMISSIONER UECKER – YES.  
COMMISSIONER LIESMANN – YES.  
COMMISSIONER RILEY – YES. MOTION CARRIED. 5/0

**ITEM 4** – Consider ratifying and/or approving line-item transfers as presented. Vote on any action taken. (Judge Bray)

There were none presented. No action required.

**ITEM 5** – Consider ratifying and/or approving the outstanding bills. Vote on any action taken. (Judge Bray)

COMMISSIONER LIESMANN made the motion ratifying the bills in the amount of \$76,147.03 and approving the outstanding bills in the amount of \$951,938.07, seconded by Commissioner Uecker. Judge Bray called for discussion and vote.

JUDGE BRAY – YES.  
COMMISSIONER WEIR – YES.  
COMMISSIONER UECKER – YES.  
COMMISSIONER LIESMANN – YES.  
COMMISSIONER RILEY – YES. MOTION CARRIED. 5/0

**ITEM 6** – Update on the cupola. Informational item only. (Judge Bray)

**ITEM 7** – Update on the a/c replacement at the LEC. Informational item only. (Judge Bray)

**ITEM 8** – Declare 1 PTZ camera as surplus property and authorization to destroy. Vote on any action taken. (Judge Bray)

COMMISSIONER RILEY makes the motion to declare 1 PTZ camera as surplus property and authorize to destroy, seconded by Commissioner Uecker. Judge Bray called for discussion and vote.

JUDGE BRAY – YES.  
COMMISSIONER WEIR – YES.  
COMMISSIONER UECKER – YES.  
COMMISSIONER LIESMANN – YES.  
COMMISSIONER RILEY – YES. MOTION CARRIED. 5/0

**ITEM 9** – Consider authorization for the County Judge to enroll elected officials and employees to TAC’s Annual Cybersecurity Training Course for FY2024-25 as required by Tx Gov’t code 2054.5191. Vote on any action taken. (Judge Bray)

COMMISSIONER LIESMANN makes the motion authorizing the County Judge to enroll elected officials and employees to TAC’s Annual Cybersecurity Training Course for FY2024-25 as required by Tx Gov’t code 2054.5191, seconded by Commissioner Riley. Judge Bray called for discussion and vote.

JUDGE BRAY – YES.  
COMMISSIONER WEIR – YES.  
COMMISSIONER UECKER – YES.  
COMMISSIONER LIESMANN – YES.  
COMMISSIONER RILEY – YES. MOTION CARRIED. 5/0

**ITEM 10** – Consider proposed holiday schedule for 2025. Vote on any action taken. (Judge Bray)

COMMISSIONER RILEY makes the motion to approve the proposed holiday schedule for 2025, seconded by Commissioner Weir. Judge Bray called for discussion and vote.

JUDGE BRAY – YES.  
COMMISSIONER WEIR – YES.  
COMMISSIONER UECKER – YES.  
COMMISSIONER LIESMANN – YES.  
COMMISSIONER RILEY – YES. MOTION CARRIED. 5/0

**ITEM 11** – Consider proposed 2025 drop off calendar for new subdivision applications. Vote on any action taken. (Judge Bray)

COMMISSIONER UECKER makes the motion to accept the proposed 2025 drop off calendar for new subdivision applications, seconded by Commissioner Riley. Judge Bray called for discussion and vote.

JUDGE BRAY – YES.  
COMMISSIONER WEIR – YES.  
COMMISSIONER UECKER – YES.  
COMMISSIONER LIESMANN – YES.

COMMISSIONER RILEY – YES. MOTION CARRIED. 5/0

**ITEM 12** – Consider approval of specs and purchase of three (3) Motorola APX6000 handheld radios as outlined in the Capital Equipment section of the FY24-25 budget, pending County Attorney approval. Vote on any action taken. (Judge Bray & Sheriff Jackson)

COMMISSIONER RILEY moves that we approve the specs and purchase of three (3) Motorola APX6000 handheld radios as outlined in the Capital Equipment section of the FY24-25 budget, pending County Attorney approval, seconded by Commissioner Uecker. Judge Bray called for discussion and vote.

JUDGE BRAY – YES.

COMMISSIONER WEIR – YES.

COMMISSIONER UECKER – YES.

COMMISSIONER LIESMANN – YES.

COMMISSIONER RILEY – YES. MOTION CARRIED. 5/0

**ITEM 13** – Consider approval of specs and purchase of three (3) Motorola APX6500 vehicle radios as outlined in the Capital Equipment section of the FY24-25 budget, pending County Attorney approval. Vote on any action taken. (Judge Bray & Sheriff Jackson)

COMMISSIONER RILEY moves to approve the specs and purchase of three (3) Motorola APX6500 vehicle radios as outlined in the Capital Equipment section of the FY24-25 budget, pending County Attorney approval, seconded by Commissioner Weir. Judge Bray called for discussion and vote.

JUDGE BRAY – YES.

COMMISSIONER WEIR – YES.

COMMISSIONER UECKER – YES.

COMMISSIONER LIESMANN – YES.

COMMISSIONER RILEY – YES. MOTION CARRIED. 5/0

**ITEM 14** – Consider approval of specs and purchase of three (3) vehicles and equipment as outlined in the Capital Equipment section of the FY24-25 budget, pending County Attorney approval. Vote on any action taken. (Judge Bray & Sheriff Jackson)

COMMISSIONER RILEY moves to approve the specs and purchase of three (3) vehicles and equipment as outlined in the Capital Equipment section of the FY24-25 budget, pending County Attorney approval, seconded by Commissioner Uecker. Judge Bray called for discussion and vote.

JUDGE BRAY – YES.

COMMISSIONER WEIR – YES.

COMMISSIONER UECKER – YES.

COMMISSIONER LIESMANN – YES.

COMMISSIONER RILEY – YES. MOTION CARRIED. 5/0

**ITEM 15** – Consider approval of specs and proposal from Anchor Group, for galvanized chain link fence and slide gate operators for the upper parking lot at the LC as outlined in capital outlay section of the FY24-25 budget. Supplemental funds from Sheriff's Office Special Fund. Vote on any action taken. (Judge Bray & Sheriff Jackson)

COMMISSIONER LIESMANN makes the motion to approve the specs and proposal from Anchor Group, for galvanized chain link fence and slide gate operators for the upper parking lot at the LC as outlined in capital outlay section of the FY24-25 budget with supplemental funds from Sheriff's Office Special Fund, seconded by Commissioner Riley. Judge Bray called for discussion and vote.

JUDGE BRAY – YES.

COMMISSIONER WEIR – YES.

COMMISSIONER UECKER – YES.

COMMISSIONER LIESMANN – YES.

COMMISSIONER RILEY – YES. MOTION CARRIED. 5/0

**ITEM 16** – Consider approval of specs and purchase of seven (7) Taser 10's as outlined in the Sheriff's Office section of the FY24-25 budget. Vote on any action taken. (Judge Bray & Sheriff Jackson)

COMMISSIONER RILEY moves to approve the specs and purchase of seven (7) Taser 10's as outlined in the Sheriff's Office section of the FY24-25 budget, seconded by Commissioner Uecker. Judge Bray called for discussion and vote.

JUDGE BRAY – YES.

COMMISSIONER WEIR – YES.

COMMISSIONER UECKER – YES.

COMMISSIONER LIESMANN – YES.

COMMISSIONER RILEY – YES. MOTION CARRIED. 5/0

**ITEM 17** – Consider authorization for the County Judge to accept and sign the 13<sup>th</sup> Amendment to Master Services Purchasing Agreement and approve specs and purchase of three (3) AXON Body Cameras as outlined in the Sheriff's Office section of the FY24-25 budget. Vote on any action taken. (Judge Bray & Sheriff Jackson)

COMMISSIONER WEIR moves to authorize the County Judge to accept and sign the 13<sup>th</sup> Amendment to Master Services Purchasing Agreement and approve specs and purchase of three (3) AXON Body Cameras as outlined in the Sheriff's Office section of the FY24-25 budget, seconded by Commissioner Liesmann. Judge Bray called for discussion and vote.

JUDGE BRAY – YES.

COMMISSIONER WEIR – YES.

COMMISSIONER UECKER – YES.

COMMISSIONER LIESMANN – YES.

COMMISSIONER RILEY – YES. MOTION CARRIED. 5/0

**ITEM 18** – Consider authorization for the County Judge to accept and sign Sustainable Security Solutions Proposal as outlined in the LEC Maintenance section of the FY24-25 budget. Vote on any action taken. (Judge Bray & Sheriff Jackson)

COMMISSIONER RILEY votes to authorize the County Judge to accept and sign Sustainable Security Solutions Proposal as outlined in the LEC Maintenance section of the FY24-25 budget, seconded by Commissioner Weir. Judge Bray called for discussion and vote.

JUDGE BRAY – YES.

COMMISSIONER WEIR – YES.

COMMISSIONER UECKER -YES.

COMMISSIONER LIESMANN – YES.

COMMISSIONER RILEY – YES. MOTION CARRIED. 5/0

**ITEM 19** – Discussion and action regarding septic application process, filing and fees. Vote on any action taken. (Judge Bray)

No action taken at this time. To be on an upcoming agenda.

**ITEM 20** – Approve the specs and purchase of a John Deere 324P-Tier Compact Wheel Loader as outlined in the Capital Equipment section of the FY24-25 budget. Vote on any action taken. (Commissioner Weir)

COMMISSIONER WEIR would like to make the motion to approve the specs and purchase of a John Deere 324 P-Tier Compact Wheel Loader as outlined in the Capital Equipment section of the FY24-25 budget, seconded by Commissioner Riley. Judge Bray called for discussion and vote.

JUDGE BRAY – YES.

COMMISSIONER WEIR – YES.

COMMISSIONER UECKER – YES.

COMMISSIONER LIESMANN – YES.

COMMISSIONER RILEY – YES. MOTION CARRIED. 5/0

**ITEM 21** – Discussion and action to add additional vendors for the FY24-25 materials bid. Vote on any action taken. (Commissioner Liesmann)

COMMISSIONER LIESMANN makes the motion to add additional vendors for the FY24-25 materials bid, those companies are Johnson City Crushed Stone and Rhino Hot Mix LLC, seconded by Commissioner Uecker. Judge Bray called for discussion and vote.

JUDGE BRAY – YES.

COMMISSIONER WEIR – YES.

COMMISSIONER UECKER -YES.

COMMISSIONER LIESMANN -YES.

COMMISSIONER RILEY – YES. MOTION CARRIED. 5/0

**ITEM 22** – Consider approval of the United Rental agreement for a Man-Lift to install Christmas lights, pending County Attorney approval. Vote on any action taken.  
(Commissioner Liesmann)

COMMISSIONER LIESMANN made the motion to approve the United Rental agreement for a Man-Lift to install Christmas lights with those two (2) deals that she will address, seconded by Commissioner Uecker. Judge Bray called for discussion and vote.

JUDGE BRAY – YES.

COMMISSIONER WEIR – YES.

COMMISSIONER UECKER – YES.

COMMISSIONER LIESMANN – YES.

COMMISSIONER RILEY – YES. MOTION CARRIED. 5/0

**ITEM 23** – Approve the specs and purchase of a John Deere 335P Compact Track Loader as outlined in the Capital Equipment section of the FY24-25 budget. Vote on any action taken.  
(Commissioner Riley)

COMMISSIONER RILEY makes the motion to approve the specs and purchase of a John Deere 335P Compact Tract Loader as outlined in the Capital Equipment section of the FY24-25 budget, seconded by Commissioner Liesmann. Judge Bray called for discussion and vote.

JUDGE BRAY – YES.

COMMISSIONER WEIR – YES.

COMMISSIONER UECKER – YES.

COMMISSIONER LIESMANN – YES.

COMMISSIONER RILEY – YES. MOTION CARRIED. 5/0

**ITEM 24** – Consider burn ban. Vote on any action taken. (Judge Bray)

COMMISSIONER UECKER makes the motion to put burn ban on until December 10, 2024, at noon, seconded by Commissioner Riley. Judge Bray called for discussion and vote.

JUDGE BRAY – YES.

COMMISSIONER WEIR – YES.

COMMISSIONER UECKER – YES.

COMMISSIONER LIESMANN – YES.

COMMISSIONER RILEY – YES. MOTION CARRIED. 5/0

**ITEM 25** – Adjourn.

COMMISSIONER UECKER made the motion to adjourn, seconded by Commissioner Weir. Judge Bray called for discussion and vote.

JUDGE BRAY – YES.

COMMISSIONER WEIR – YES.

COMMISSIONER UECKER -YES.

COMMISSIONER LIESMANN -YES.  
COMMISSIONER RILEY – YES. MOTION CARRIED. 5/0

The meeting adjourned at 10:00 A.M.

The above and foregoing minutes were examined and approved in Open Court this \_\_\_\_\_ day of \_\_\_\_\_, 2024.

I, Laura Walla, County Clerk, Blanco County, Texas attest that the foregoing is a true and correct accounting of the Commissioner’s Court authorized proceedings for November 12<sup>th</sup>, 2024.

\_\_\_\_\_  
Laura Walla, County Clerk, Blanco County

DRAFT



**SPECIAL MEETING – November 14, 2024**

On this the 14<sup>th</sup> day of November 2024 at 2:00 P.M. the Honorable Commissioners Court of Blanco County convened in a SPECIAL MEETING. Due to the planned renovations, the courtroom is closed, after notice to the public, the meeting was held in the Courthouse Annex Hoppe Room in Johnson City with the following members to-wit.

BRETT BRAY	COUNTY JUDGE
TOMMY WEIR	COMMISSIONER PCT. 1
EMIL UECKER	COMMISSIONER PCT. 2
CHRIS LIESMANN	COMMISSIONER PCT. 3
CHARLES RILEY	COMMISSIONER PCT. 4
LAURA WALLA	COUNTY CLERK

---

**1. Call to order and roll call.**

Judge Bray and all four County Commissioners are in attendance.

**2. Pledge of Allegiance(s).**

**3. Invocation**

Led by Commissioner Uecker.

**4. PUBLIC COMMENTS – opportunity for the general public to address the Court on any matter. Comments are limited to 3 minutes.**

**5. Canvass the votes from the general election held on November 5, 2024. Vote on any action taken. (Judge Bray)**

COMMISSIONER LIESMANN makes the motion to approve the canvass of the votes for the general election as presented, seconded by Commissioner Riley. Judge Bray called for discussion and vote.

JUDGE BRAY -YES.

COMMISSIONER WEIR – YES.

COMMISSIONER UECKER – YES.

COMMISSIONER LIESMANN – YES.

COMMISSIONER RILEY – YES. MOTION CARRIED. 5/0

**6. Adjourn.**

COMMISSIONER UECKER made the motion to adjourn, seconded by Commissioner Liesmann. Judge Bray called for discussion and vote.

JUDGE BRAY – YES.  
COMMISSIONER WEIR – YES.  
COMMISSIONER UECKER – YES.  
COMMISSIONER LIESMANN – YES.  
COMMISSIONER RILEY – YES. MOTION CARRIED. 5/0

The above and foregoing minutes were examined and approved in Open Court this \_\_\_\_\_ day of November 2024.

I Laura Walla, County Clerk, Blanco County, Texas attest that the foregoing is a true and correct accounting of the Commissioner's Court authorized proceedings for November 14, 2024.

---

County Clerk and Ex-Officio Member of Commissioner's Court, Blanco County, Texas

DRAFT

# **No Line-Item Transfers**

# Blanco County Commissioners' Court

November 26, 2024

## Invoice File Listing By Fund for Approval

Fund	Description	Disbursement
010	General Fund	\$ 225,795.18
015	Road & Bridge Fund	\$ 4,492.02
017	Records Management Clerk	\$ 16,189.24
027	County Clerk Archive Fund	\$ 5,231.80
040	County Court Technology Fund	\$ 199.99
045	Jail Inmate Commissary Fund	\$ 126.79
049	Exhibit Hall	\$ 110.75
<b>Total</b>		<b>\$ 252,145.77</b>

The attached list of Claims Payable have been examined & approved for payment by the Assistant County Auditor as provided by the Texas LGC 113.064 & 113.065

Attest Asst. County Auditor:  Date 11-27-24

The attached list of Claims Payable have been examined & approved for payment by the Commissioners' Court as provided by the Texas LGC 115.021 & 115.022

County Judge \_\_\_\_\_ Date \_\_\_\_\_

Commissioner Pct 1 \_\_\_\_\_ Commissioner Pct 3 \_\_\_\_\_

Commissioner Pct 2 \_\_\_\_\_ Commissioner Pct 4 \_\_\_\_\_

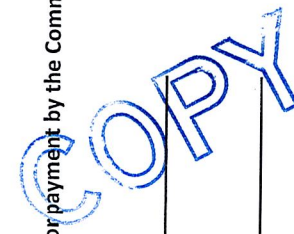

DEPARTMENT				
NAME-OF-VENDOR	INVOICE-NO	S	DESCRIPTION-OF-INVOICE	AMOUNT
0411-ELECTIONS ADMINISTRATOR				
ADDISON ALLEN	90266	A	POLLWORKER PAYROLL	356.25
BRENDA THOMAS	90267	A	POLLWORKER PAYROLL	2,760.00
BRENDA WOMACK	90280	A	POLLWORKER PAYROLL	686.25
BRENDA WOMACK	90293	A	POLLWORKER PAYROLL	686.25
CANDY RUDY	90294	A	POLLWORKER PAYROLL	1,548.75
CAROLYN GEILER	90288	A	POLLWORKER PAYROLL	217.50
CHERYL WILKERSON	90287	A	POLLWORKER PAYROLL	198.75
CHRISTINE REINECKE-LANGFELD	90281	A	POLLWORKER PAYROLL	225.00
CHRISTINE THERIOT	90289	A	POLLWORKER PAYROLL	746.25
D 'ANNE WELCH	90302	A	POLLWORKER PAYROLL	367.50
DAVID SCHNEIDER	90269	A	POLLWORKER PAYROLL	915.00
DEBI WHITTKOHL	90282	A	POLLWORKER PAYROLL	2,214.38
DENISE ADAMS	90299	A	POLLWORKER PAYROLL	412.50
DENISE PORTER	90284	A	POLLWORKER PAYROLL	202.50
ELECTION SYSTEMS & SOFTWARE	90372	A	INV#CD2108212 EA	2,154.00
ELECTION SYSTEMS & SOFTWARE	90373	A	INV#CD2108655 EA	290.74
ELECTION SYSTEMS & SOFTWARE	90374	A	INV#CD218134 EA	555.00
ERIC PORTER	90285	A	POLLWORKER PAYROLL	202.50
FRANCIELA MARIN SMITH	90295	A	POLLWORKER PAYROLL	150.00
FRANK BLAGG	90301	A	POLLWORKER PAYROLL	367.50
JANICE K PHILLIPS	90274	A	POLLWORKER PAYROLL	926.25
JILL CHRISTAL	90277	A	POLLWORKER PAYROLL	191.25
JULIA MCCOMAS	90275	A	POLLWORKER PAYROLL	240.00
KAREN MANGAN	90271	A	POLLWORKER PAYROLL	660.00
KATHLEEN DIANE RADOCHA	90272	A	POLLWORKER PAYROLL	393.75
KELLY J BARROWS	90286	A	POLLWORKER PAYROLL	1,278.75
LANCE BROWN	90292	A	POLLWORKER PAYROLL	135.00
MANDY BUCK	90276	A	POLLWORKER PAYROLL	1,260.00
MARGARET GOODMAN	90291	A	POLLWORKER PAYROLL	326.25
MARK JUELG	90270	A	POLLWORKER PAYROLL	708.75
MARY PHILLIPS	90278	A	POLLWORKER PAYROLL	2,193.75
MARY SWARD	90300	A	POLLWORKER PAYROLL	345.00
MARY UECKER	90283	A	POLLWORKER PAYROLL	198.75
MEGHAN WRIGHT	90296	A	POLLWORKER PAYROLL	1,065.00
OFFICE OF THE SECRETARY OF STATE	90391	A	INV#CSO24-2411-1113-0307 EA	325.00
PHYLLIS B RECTRO	90268	A	POLLWORKER PAYROLL	390.00
RACHELLE WILLGREN	90279	A	POLLWORKER PAYROLL	2,244.38
RALPH MERTESDORF	90273	A	POLLWORKER PAYROLL	900.00
RENAISSANCE AUSTIN HOTEL	90397	A	CONFIRMATION#1:88398559 EA	613.20
ROBERT TYSDAL	90297	A	POLLWORKER PAYROLL	735.00
RUDY BLAIR	90290	A	POLLWORKER PAYROLL	337.50
STAPLES	90398	A	INV#6017220765 EA	67.07
VICKIE BLAGG	90303	A	POLLWORKER PAYROLL	427.50
WILLIAM RECTOR	90298	A	POLLWORKER PAYROLL	536.25
DEPARTMENT TOTAL				31,755.02
0412-DISTRICT CLERK				
CELIA DOYLE	90319	A	REIMBURSEMENT	571.33
DEPARTMENT TOTAL				571.33
0425-COUNTY SHERIFF				
AMAZON CAPITAL SERVICES, INC	90308	A	INV#1QPG-CLH7-CP1F LEC	44.99
AMAZON CAPITAL SERVICES, INC	90309	A	INV#11LN-MDG9-1GYJ LEC	44.99
AMAZON CAPITAL SERVICES, INC	90311	A	INV#1H6P-QL4P-3D4D LEC	285.06
AMAZON CAPITAL SERVICES, INC	90312	A	INV#1H6P-QL4P-3D4D LEC	75.59
BLANCO COUNTY TAX ASSESSOR-COLLECT	90317	A	LICENSE TAG #1446735 LEC	7.50

DEPARTMENT

NAME-OF-VENDOR	INVOICE-NO	S	DESCRIPTION-OF-INVOICE	AMOUNT
BLANCO COUNTY TAX ASSESSOR-COLLECT	90318	A	LICENSE TAG #1223439 LEC	7.50
EXPRESS AUTOMOTIVE SERVICE	90320	A	INV#11302 LEC	99.10
EXPRESS AUTOMOTIVE SERVICE	90321	A	INV#11311 LEC	112.05
EXPRESS AUTOMOTIVE SERVICE	90376	A	INV#11476 LEC	112.17
EXPRESS AUTOMOTIVE SERVICE	90377	A	INV#11484 LEC	70.13
GT DISTRIBUTORS, INC	90324	A	INV#UNIV0058423 LEC	692.92
GT DISTRIBUTORS, INC	90325	A	INV#INV1023603 LEC	39.94
MADDISON MCIALWAIN	90329	A	REIMBURSEMENT	150.75
MONTGOMERY COUNTY HOSPITAL DISTRICT	90243	A	INV #3303 LEC	252.00
NORTH BLANCO COUNTY EMS	90246	A	PATIENT #08141990 JAIL	424.72
PANASONIC CONNECT NORTH AMERICA PRO	90337	A	INV#PLR3408547 LEC	1,035.71
PAY AND SAVE INC.	90338	A	ACCT#137002 LEC	5.99
PAY AND SAVE INC.	90339	A	ACCT#137002 LEC	23.56
PEDERNALES ELECTRIC COOP	90248	A	INV #955 LEC	3,522.05
PERFORMANCE FOOD SERVICE	90348	A	INV#2497720 LEC	1,530.63
PERFORMANCE FOOD SERVICE	90349	A	INV#2497720 LEC	14.81
PERFORMANCE FOOD SERVICE	90350	A	INV#2504868 LEC	1,151.75
PERFORMANCE FOOD SERVICE	90351	A	INV#2504868 LEC	14.81
PETERSON TIRE	90354	A	INV#JC47078 LEC	70.00
PETERSON TIRE	90355	A	INV#JC47087 LEC	7.00
PETERSON TIRE	90356	A	INV#JC47097 LEC	7.00
PETERSON TIRE	90394	A	INV#JC47137 LEC	70.00
SECURITAS TECHNOLOGY CORP	90258	A	INV #6004636581 LEC	487.00
SOUTHERN HEALTH PARTNERS	90252	A	INV #BASE51894 JAIL	9,049.05
STEVEN A LOGSDON	90359	A	PRE-EMPLOYMENT EXAMS - RUTHERFORD,	200.00
WILLIAM RIEMENSCHNEIDER	90368	A	REIMBURSEMENT	68.34
WORKQUEST	90369	A	INV#PINV0265908 LEC	648.92
DEPARTMENT TOTAL				20,326.03
0430-COUNTY TREASURER				
AMAZON CAPITAL SERVICES, INC	90306	A	INV#1YY6-37WK-7JWV CO TREAS	46.65
PERRY OFFICE PLUS	90392	A	INV#IN-1564602 CO TREAS	410.30
DEPARTMENT TOTAL				456.95
0435-INDIGENT HEALTH CARE				
SCOTT & WHITE HOSPITAL	90251	A	PATIENT #03122014	118.95
DEPARTMENT TOTAL				118.95
0440-COUNTY EXTENSION AGENCY				
CHARLIE CANTRELL	90403	A	FERAL HOG ABATEMENT	590.00
ZEB MILLER	90402	A	FERAL HOG ABATEMENT	150.00
DEPARTMENT TOTAL				740.00
0445-EMERGENCY MANAGEMENT				
AMAZON CAPITAL SERVICES, INC	90370	A	INV#1L36-WY41-7XDK ER MGMT	156.57
DEPARTMENT TOTAL				156.57
0450-JUDICIAL EXPENSES				
33RD & 424TH JUDICIAL DISTRICTS CSC	90229	A	OCTOBER 2024	400.13
BLANCO CO CHILD PROTECTION BD	90231	A	3 JURY DONATIONS	180.00
HILL COUNTRY CHILD ADVOCACY CT	90232	A	1 JURY DONATIONS	60.00
PERRY THOMAS	90250	A	CASE #1837	400.00
DEPARTMENT TOTAL				1,040.13
0451-DISTRICT JUDGE				
ALAN GARRETT	90254	A	JUVENILE BOARD COMP	100.00
BURNET COUNTY TREASURER	90233	A	INV #DC241031-1 DIST. JUDGES	4,556.94

DEPARTMENT				
NAME-OF-VENDOR	INVOICE-NO	S	DESCRIPTION-OF-INVOICE	AMOUNT
EVAN C. STUBBS	90255	A	JUVENILE BOARD COMP., 424TH	100.00
DEPARTMENT TOTAL				4,756.94
0452-DISTRICT ATTORNEY				
BURNET COUNTY TREASURER	90234	A	INV #DA241031-1 DIST. ATTORNEY	19,842.22
DEPARTMENT TOTAL				19,842.22
0453-JUVENILE PROBATION				
JUVENILE PROBATION DEPT	90240	A	NOVEMBER 2024	6,144.69
DEPARTMENT TOTAL				6,144.69
0500-COURTHOUSE EXPENSES				
ALAMO AREA COUNCIL OF GOVERNMENTS	90259	A	INV #14851 MCMAN	1,900.00
AMAZON CAPITAL SERVICES, INC	90305	A	INV#1GMT-XCW7-6Y1F	24.47
BILL'S LOCK & KEY	90315	A	INV#31481 N.ANNEX	145.00
CANON FINANCIAL SERVICES, INC.	90235	A	INV #36175957 LEC	37.92
CHARTER COMMUNICATIONS HOLDINGS,LLC	90236	A	INV #184482901110724 LEC	1,682.79
CHARTER COMMUNICATIONS HOLDINGS,LLC	90237	A	INV #184482801110724 COURTHOUSE	1,406.38
CHARTER COMMUNICATIONS HOLDINGS,LLC	90238	A	INV #185859601110724 OLD MANOR RD	299.13
EMIL UECKER	90375	A	REIMBURSEMENT	99.89
GRAVES HUMPHRIES, STAHL, LIMITED	90239	A	REPORT #CAS017 JP 4	501.91
HILL COUNTRY WIRELESS & TECHNOLOGY	90260	A	1040-20241120-1 ADULT PROBATION	52.00
HILL COUNTRY WIRELESS & TECHNOLOGY	90261	A	2492-20241120-1 ELECTIONS	50.00
HILL COUNTRY WIRELESS & TECHNOLOGY	90262	A	3406-20241120-1 PCT 2	27.00
HILL COUNTRY WIRELESS & TECHNOLOGY	90263	A	4235-20241120-1 OLD JAIL	27.00
HILL COUNTRY WIRELESS & TECHNOLOGY	90264	A	4450-20241120-1 RECYCLING	27.00
HYE PIPE & FEED	90326	A	INV#3491747	274.41
HYE PIPE & FEED	90327	A	INV#3491748	75.68
JOHNSON CITY PUBLICATIONS LP	90381	A	INV#49346	71.25
JOHNSON CITY PUBLICATIONS LP	90382	A	INV#49347	74.25
MOURSUND INSURANCE AGENCY	90244	A	INV #24707 COWSERT BOND	50.00
NAVITAS CREDIT CORP.	90245	A	CONTRACT #20102679-1 PHONES	1,402.00
OFFICESUPPLY.COM	90330	A	INV#6185088	449.92
PAY AND SAVE INC.	90340	A	ACCT#137002 LEC	11.58
PAY AND SAVE INC.	90341	A	ACCT#137354 MAINTENANCE	119.44
PAY AND SAVE INC.	90342	A	ACCT#137354 MAINTENANCE	7.98
PAY AND SAVE INC.	90343	A	ACCT#137354 MAINTENANCE	3.99
PAY AND SAVE INC.	90344	A	ACCT#137354 MAINTENANCE	91.75
PEDERNALES ELECTRIC COOP	90249	A	INV #955 COUNTY	3,550.89
REEH PLUMBING	90357	A	MAINTENANCE LEC	8,005.00
SAN JUANA M. SALAZAR	90304	A	CUSTODIAL SERVICES SOUTH ANNEX	200.00
STAN KLEIN, AIA NCARB	90253	A	INV #24-0099 CUPOLA	5,253.11
THOMAS WEIR	90366	A	REIMBURSEMENT	123.17
VERTICAL BRIDGE S3 ASSETS, LLC	90257	A	INV #-00971045 MOUNTAIN TOP	1,752.10
VESTED NETWORKS	90256	A	INV #15321	54.00
DEPARTMENT TOTAL				27,851.01
0505-MAINTENANCE DEPARTMENT				
HUCKLEBERRY RANCH LLC	90401	A	INV #2663	140.00
PAY AND SAVE INC.	90345	A	ACCT#137354 MAINTENANCE	10.99
PAY AND SAVE INC.	90346	A	ACCT#137354 MAINTENANCE	140.94
DEPARTMENT TOTAL				291.93
0520-JUSTICE OF THE PEACE #4				
NORTHEAST TEXAS DATA CORP.	90247	A	REPORT #CAS017 JP 4	40.00
POSTMASTER/STAMPS	90400	A	POSTAGE	73.00
DEPARTMENT TOTAL				113.00
0530-CONSTABLE PCT #4				

DEPARTMENT

NAME-OF-VENDOR	INVOICE-NO	S	DESCRIPTION-OF-INVOICE	AMOUNT
AXON ENTERPRISE, INC	90230	A	INV #INUS290133 CONSTABLE #4	951.94
JOSH BUCY	90328	A	REIMBURSEMENT	48.47
DEPARTMENT TOTAL				1,000.41
0550-RECYCLING COORDINATOR				
WASTE CONNECTIONS LONE STAR, INC	90367	A	INV#13711389V156 RECYCLE	630.00
DEPARTMENT TOTAL				630.00
0560-GENERAL FUND CAPITAL EQUIPMENT				
SILSBEE FORD, INC	90358	A	INV#39002F CONST 4	110,000.00
DEPARTMENT TOTAL				110,000.00
FUND TOTAL				225,795.18



DEPARTMENT				
NAME-OF-VENDOR	INVOICE-NO	S	DESCRIPTION-OF-INVOICE	AMOUNT
0540-R&B PCT #1				
ARROW-MAGNOLIA INTERNATIONAL, INC.	90313	A	INV#IV24005105 PCT 1	755.15
BLANCO COUNTY TAX ASSESSOR-COLLECT	90371	A	LICENSE TAG #1446744 PCT 1	7.50
JONATHAN CAMPBELL	90383	A	INV#1453 PCT 1	478.13
OUTLAW LUMBER & HARDWARE, LLC	90331	A	INV#133301 PCT 1	7.77
OUTLAW LUMBER & HARDWARE, LLC	90332	A	INV#134203 PCT 1	66.29
OUTLAW LUMBER & HARDWARE, LLC	90333	A	INV#133515 PCT 1	37.73
PETERSON TIRE	90393	A	INV#BL56696 PCT 1	7.00
THIRD COAST DISTRIBUTING, LLC	90360	A	INV#979963 PCT 1	47.48
THOMAS WEIR	90365	A	REIMBURSEMENT	42.79
DEPARTMENT TOTAL				1,449.84
0550-R&B PCT #2				
ODIORNE FEED/RANCH SUPPLY INC	90385	A	INV#217922 PCT 2	14.00
ODIORNE FEED/RANCH SUPPLY INC	90386	A	INV#218441 PCT 2	70.00
ODIORNE FEED/RANCH SUPPLY INC	90387	A	INV#218889 PCT 2	67.00
ODIORNE FEED/RANCH SUPPLY INC	90388	A	INV#218908 PCT 2	18.00
ODIORNE FEED/RANCH SUPPLY INC	90389	A	INV#218968 PCT 2	25.00
ODIORNE FEED/RANCH SUPPLY INC	90390	A	FINANCE CHG 485646 PCT 2	3.27
PETERSON TIRE	90395	A	INV#JC46878 PCT 2	7.00
PETERSON TIRE	90396	A	INV#JC46900 PCT 2	20.00
DEPARTMENT TOTAL				224.27
0560-R&B PCT #3				
FORD & CREW HOME AND HARDWARE	90322	A	INV#14988/1 PCT 3	80.16
FORD & CREW HOME AND HARDWARE	90378	A	INV#25201/1 PCT 3	142.83
FORD & CREW HOME AND HARDWARE	90379	A	INV#25212/1 PCT 3	78.49
FORD & CREW HOME AND HARDWARE	90380	A	INV#25213/1 PCT 3	2.60
FRITZTOWN DIESEL & TRUCK SERVICE	90323	A	INV#00027226 PCT 3	217.50
PETERSON TIRE	90352	A	INV#JC47101 PCT 3	470.00
THIRD COAST DISTRIBUTING, LLC	90399	A	INV#154213 PCT 3	150.72
DEPARTMENT TOTAL				1,142.30
0570-R&B PCT #4				
ARROW-MAGNOLIA INTERNATIONAL, INC.	90314	A	INV#IV24005105 PCT 4	755.14
BLANCO COUNTY TAX ASSESSOR-COLLECT	90316	A	LICENSE TAG #9049764 PCT 4	7.50
JONATHAN CAMPBELL	90384	A	INV#1453 PCT 4	478.14
OUTLAW LUMBER & HARDWARE, LLC	90334	A	INV#133250 PCT 4	94.97
OUTLAW LUMBER & HARDWARE, LLC	90335	A	INV#133461 PCT 4	14.99
OUTLAW LUMBER & HARDWARE, LLC	90336	A	INV#134574 PCT 4	4.79
PETERSON TIRE	90353	A	INV#BL56666 PCT 4	7.00
THIRD COAST DISTRIBUTING, LLC	90361	A	INV#977803 & CREDIT PCT 4	190.14
THIRD COAST DISTRIBUTING, LLC	90362	A	INV#978224 PCT 4	43.98
THIRD COAST DISTRIBUTING, LLC	90363	A	INV#979422 PCT 4	22.99
THIRD COAST DISTRIBUTING, LLC	90364	A	INV#980030 PCT 4	55.97
DEPARTMENT TOTAL				1,675.61
FUND TOTAL				4,492.02

-----  
DEPARTMENT

NAME-OF-VENDOR	INVOICE-NO	S	DESCRIPTION-OF-INVOICE	AMOUNT
0400-RECORDS MANAGEMENT CLERK EXPENSES				
KOFILE TECHNOLOGIES, INC	90241	A	INV #KT-017639 DIST CLERK	16,189.24
DEPARTMENT TOTAL				16,189.24
FUND TOTAL				16,189.24

---

DEPARTMENT	NAME-OF-VENDOR	INVOICE-NO	S	DESCRIPTION-OF-INVOICE	AMOUNT
0400-EXPENSES					
	KOFILE TECHNOLOGIES, INC	90242	A	INV #KT-018047 CO CLERK	5,231.80
	DEPARTMENT TOTAL				5,231.80
	FUND TOTAL				5,231.80

DEPARTMENT

NAME-OF-VENDOR	INVOICE-NO	S	DESCRIPTION-OF-INVOICE	AMOUNT
0400-EXPENSES				
AMAZON CAPITAL SERVICES, INC	90307	A	INV#1HQN-PJ4L-D47Y	199.99
DEPARTMENT TOTAL				199.99
FUND TOTAL				199.99

-----  
DEPARTMENT

NAME-OF-VENDOR	INVOICE-NO	S	DESCRIPTION-OF-INVOICE	AMOUNT
0400-JAIL INMATE COMMISSARY EXPENSES				
AMAZON CAPITAL SERVICES, INC	90310	A	INV#1H6P-QL4P-3D4D LEC	126.79
DEPARTMENT TOTAL				126.79
FUND TOTAL				126.79

DEPARTMENT

NAME-OF-VENDOR	INVOICE-NO	S	DESCRIPTION-OF-INVOICE	AMOUNT
0400-EXPENSES				
HILL COUNTRY WIRELESS & TECHNOLOGY	90265	A	4175-20241120-1 FAIR GROUNDS	54.00
PAY AND SAVE INC.	90347	A	ACCT#137354 MAINTENANCE	56.75
DEPARTMENT TOTAL				110.75
FUND TOTAL				110.75

---

DEPARTMENT	NAME-OF-VENDOR	INVOICE-NO	S	DESCRIPTION-OF-INVOICE	AMOUNT
	GRAND TOTAL				252,145.77

# Blanco County Commissioners' Court

November 26, 2024

## Invoice File Listing By Fund to Ratify

Fund	Description	Disbursement
010	General Fund	\$ 4,397.44
021	HOT Tax Fund	\$ 12,500.00
<b>Total</b>		<b>\$ 16,897.44</b>

The attached list of Claims Payable have been examined & approved for payment by the Assistant County Auditor as provided by the Texas LGC 113.064 & 113.065

Attest Asst. County Auditor:

*Madeline Dillard* Date 11-27-24

The attached list of Claims Payable have been examined & approved for payment by the Commissioners' Court as provided by the Texas LGC 115.021 & 115.022

County Judge \_\_\_\_\_

Date \_\_\_\_\_

Commissioner Pct 1 \_\_\_\_\_

Commissioner Pct 3 \_\_\_\_\_

Commissioner Pct 2 \_\_\_\_\_

Commissioner Pct 4 \_\_\_\_\_

**COPY**



DEPARTMENT				
NAME-OF-VENDOR	INVOICE-NO	S	DESCRIPTION-OF-INVOICE	AMOUNT
0440-COUNTY EXTENSION AGENCY				
CHAD SCHNITZ	90221	R	FERAL HOG ABATEMENT	220.00
DANNY M TURNER	90222	R	FERAL HOG ABATEMENT	90.00
DEPARTMENT TOTAL				310.00
0500-COURTHOUSE EXPENSES				
BLANCO COUNTY PUBLICATIONS LP	90220	R	INV #3109 33RD & 424TH JUDICIAL	99.00
GREAT AMERICA FINANCIAL SERVICES	90227	R	INV #37844424 COPIERS	2,972.99
GVTC	90223	R	SERVICVE ID #830-833-3209 SO ANNEX	462.89
GVTC	90224	R	SERVICVE ID #830-833-3209 SO ANNEX	134.90
DEPARTMENT TOTAL				3,669.78
0505-MAINTENANCE DEPARTMENT				
HUCKLEBERRY RANCH LLC	90225	R	INV #2644 LAWN MAINTENANCE	180.00
DEPARTMENT TOTAL				180.00
0525-CONSTABLE PCT #1				
VERIZON WIRELESS	90228	R	INV #9977676490 CONSTABE #1	237.66
DEPARTMENT TOTAL				237.66
FUND TOTAL				4,397.44

-----  
DEPARTMENT

NAME-OF-VENDOR	INVOICE-NO	S	DESCRIPTION-OF-INVOICE	AMOUNT
0400-HOT TAX EXPENSES				
LIGHTS SPECTACULAR	90226	R	HOTEL OCCUPANCY TAX FUNDS 24-25	12,500.00
DEPARTMENT TOTAL				12,500.00
FUND TOTAL				12,500.00

DEPARTMENT

NAME-OF-VENDOR

INVOICE-NO

S

DESCRIPTION-OF-INVOICE

AMOUNT

GRAND TOTAL

16,897.44

## RENTAL AGREEMENT

This Rental Agreement is entered into on this \_\_\_\_\_ day of \_\_\_\_\_, 2024, by and between COUNTY OF BLANCO ("County"), and the ARMADILLO PSB, LLC d/b/a PECAN STREET BREWING ("Renter").

### RENTAL OF PREMISES

In consideration of the mutual covenants and agreements of this Rental Agreement, and other good and valuable consideration, County agrees to rent to Renter the outside grounds of the Courthouse, located at 101 E. Pecan Drive, Johnson City, Texas 78636 (the "Premises"). The Premises shall also include the parking spaces directly adjacent to the Courthouse grounds along E. Pecan Dr. and N. Avenue G. The rental term shall be effective from Saturday, October 18, 2025, at 12:00 a.m. through 11:59 p.m.

### CONSIDERATION

Renter is sponsoring a Classic Car Show on October 18, 2025, (the "Event") and desires to rent the Premises for the Event. Renter has contracted with certain vendors for the Event and desires for the County to permit the vendors to use the premises. County desires to rent the Premises and recognizes that the Event will bring an influx of tourists to the county.

### CONDITIONS

1. Renter shall obtain all necessary variances and permits for the Event.
2. Renter shall ensure that all vendors have obtained the necessary variances and permits.
3. Renter and all vendors shall comply with all State laws.
4. Neither Renter, nor any vendor, shall use a means to secure tents or other structures or equipment that will damage the Premises.
5. Tear down and set up must occur during the rental term set forth above.
6. Renter shall provide a minimum of 8 trash cans (2 on each corner) and shall empty them as needed.
7. Renter may put portable restrooms in the parking area; provided, Renter complies with all State regulations.
8. Neither Renter, nor any vendor, shall use any excessive heat, chemicals, marking devices, paint, adhesive or any other substance or device which could damage the Premises.
9. Renter shall provide County with proof of property and liability insurance for the Event.
10. The Premises shall be left in the same or better condition as it currently is in.
11. Renter shall advise all vendors of the Conditions of this contract and ensure that they comply with the Conditions.
12. Renter shall indemnify, defend and hold harmless County, and its employees from and against all demands, suits, judgments, settlements, claims, damages to persons and/ or property, fines, liens, losses and other liabilities, including reasonable attorneys' fees arising out of or in any way related to the Event, including claims for loss or damage to any property, or for death or injury to any individual.

THIS RENTAL AGREEMENT has been executed and acknowledged by the parties on the date and year first above written.

**COUNTY:**  
COUNTY OF BLANCO

By: \_\_\_\_\_  
Brett Bray  
Blanco County Judge

**RENTOR:**  
ARMADILLO PSB, LLC

By: \_\_\_\_\_  
Jackie Bresie  
Member

COPY

**Old Annex Retail & Office Building  
Lease Agreement  
Blanco County Texas  
January 2025**

In consideration of the Landlord's leasing of the Premises to the Tenant, the Tenant's leasing from the Landlord the Premises, and the mutual benefits and obligations conferred by this lease on the Parties, and in recognition of the receipt and sufficiency of said consideration, the Parties hereby agree to the following terms and conditions:

**I. The Parties** – Lease agreement is between Lessor under the individual/entity (hereinafter known as the "Landlord") known as Old Annex Office Solutions LLC and the Lessee under the individual/entity (hereinafter referred to as the "Tenant") known as Blanco County Texas.

**II. Premises** – The space/property being leased shall be described as: Old Annex Suites 7 & 8 at 200 N Avg G, Johnson City, TX 78636 (Hereinafter referred to as the "Premises").

**III. Term** – The term of the lease shall be 12 months beginning on the 1st day of January, 2025 and ending on the 31st day of December, 2025.

**IV. Rent** – Rent shall be paid by the 15th of every month in the amount of \$1800 for January through June and \$1900 for July through December.

**V. Security Deposit** – Previous Security Deposit of \$1800 carries over. If Tenant follows the terms and conditions of this agreement in good faith and without damaging Premises, the Security Deposit will be returned within ten (10) business days at lease expiration. Otherwise, any repairs needed for Premises will be deducted from the Security Deposit.

**VI. Improvements During Lease Term** – Tenant, with written approval from Landlord, shall be able to make improvement to Premises.

**VII. Use** – Tenant will occupy Premises for the following use(s):

Suite 7 - Agrilife Extension Service

Suite 8 - Agrilife Extension Service and/or private County office space

**VIII. Compliance** – Tenant shall comply with all federal, state, and local laws, regulations, and ordinances related to the products they sell and/or the services they provide.

**IX. Utilities and Other Expenses** – The following utilities/services are included with Rent:

1. HVAC
2. Electricity
3. Water / Sewer/ Waste
4. Internet

In the event of utility/service outages or other utility/service issues, Landlord will make every reasonable effort to resolve those issues in a timely manner. With the exception of what would reasonably be considered gross negligence, Landlord will not be held liable for outages affecting Tenant's business. Landlord will coordinate with Tenant on any planned utility outages.

**X. Landlord's Representations** – At the time of lease signing, Premises shall be properly zoned for Tenant's stated use and will be in compliance with all applicable state and federal laws and regulations. Premises shall not have been used for the storage or disposal of any toxic or hazardous substances, and Landlord has received no notice from any governmental authority concerning removal of any toxic or hazardous substances from the property.

**XI. Landlord's Responsibility** – Landlord shall maintain and make any and all necessary repairs to: (1) the roof, structural components, exterior walls, and interior common walls of Premises, and (2) the plumbing, electrical, internet access, and HVAC. Landlord will regularly clean and maintain the parking areas, common areas, and exterior of the building and remove all litter so that Premises will be kept in an attractive condition.

**XII. Tenant's Responsibility** – Tenant shall keep Premises clean and well maintained at all times, so that Premises shall be in marketable condition.

**XIII. Insurance** – Landlord agrees to carry fire and hazard related coverage insurance for Premises. Tenant agrees to carry public liability insurance that includes Landlord as an insured party for personal injury. This agreement automatically releases Landlord and Tenant from each other in reference to liability for property, loss, damage, personal injury, or anything else covered by the insurance plan. Landlord does not carry any insurance for Tenant's personal property. Tenant is responsible for insuring its personal property, as needed.

**XIV. Taxes** – Landlord is responsible for all real property taxes. Tenant is responsible for any personal/business property taxes.

**XV. Subletting** – Tenant does not have the right to sublet Premises.

**XVI. Damage to Premises** – Tenant may terminate the lease agreement if necessary repairs to Premises due to fire, flood, or any natural catastrophe keep Tenant from being open for over ninety (90) days. If Tenant is not able to be open for the ninety (90) day period due to damage to Premises, there will be no rent paid during said period.

**XVII. Default** – If Tenant defaults on the lease agreement for non-payment of rent or for any other reason, Landlord agrees to give notice to Tenant; giving Tenant the right to cure the issue(s). If Tenant does not cure the issue(s) within the amount of time stated in the notice, then Landlord has the right to take legal action.

**XVIII. Notice of Quiet Enjoyment** – During Term, Tenant has the right of quiet enjoyment of Premises.

**XIX. Holding Over** – If Tenant remains in possession of Premises after the lease agreement ends, the tenancy shall continue on a month-to-month, or “Tenancy at Will,” basis unless Landlord gives notice for Tenant to vacate.

**XX. Disagreements During the Lease Period** – If a disagreement arises during the lease period, the following actions shall take place:

Mediation with Possible Arbitration – If there is a dispute between Landlord and Tenant, all parties agree to attempt to come to an agreement through the use of an agreed upon mediator.

1. It is agreed that the cost(s) involved in hiring the mediator shall be shared equally and that each party shall cooperate in a good faith attempt to reach a resolution. Both parties agree that they shall allow the mediator thirty (30) days from the first (1<sup>st</sup>) meeting to reach a compromise before going to an arbitrator.
2. The arbitrator selected will be a third (3<sup>rd</sup>) party to be mutually agreed upon. The arbitrator shall decide all costs directed towards hiring the arbitrator.

Landlord shall not have to attend the mediation or arbitration process unless Tenant is current with the rental payments, either submitting to Landlord directly or depositing the funds in an escrow account.

**XXI. Additional Agreements** – Landlord and Tenant additionally agree to the following:

None.

**XXII. Entire Lease Agreement** – This document supersedes any other writings in relation to Premises and has authority over any oral agreements made between Landlord and Tenant.

**XXIII. Successors and Assignees** – All assignees of the parties including heirs, successors, or anyone else that may be considered is mutually bound by this lease agreement.

**XXIV. Notices** – All notices in relation to Premises or this lease agreement shall be in writing and delivered to the following physical or email address:

**Landlord**

Old Annex Office Solutions  
P.O. Box 2236  
Johnson City, TX 78636  
oldannexofficesolutions@gmail.com

**Tenant**

Blanco County Texas  
P.O. Box 387  
Johnson City, TX 78636  
charrison@co.blanco.tx.us



**XXV. Governing Law** – This lease agreement will be governed by and construed in accordance with the laws in the State of Texas.

**XXVI. Eminent Domain** – The lease automatically becomes void if Premises are taken by eminent domain. During the process, Tenant shall have to right to seek compensation per applicable Governing Law.

**XXVII. Waiver** – If either Landlord or Tenant waives any term or provision of this lease at any time, that waiver will be effective only for the specific instance and specific purpose for which the waiver was given. If either party fails to exercise or delays exercising any of its rights or remedies under this lease, that party retains the right to enforce that term or provision at a later time.

**XXVIII. Early Termination** – Early termination shall be possible under the following circumstances:

1. Tenant provides at least 60 days’ notice with a specific date of termination.
2. Tenant remains in violation of section VIII (Compliance) after being given written notice and 30 days to rectify the listed issue(s).
3. Tenant is more than 45 days past due on rent. Written notice must be given at 30 days past due and at least 15 days from the intended end date. Tenant must vacate Premises by the communicated end date. Items not picked up by the communicated end date will be considered abandoned/forfeit unless Tenant and Landlord have made other mutually agreed upon arrangements prior to communicated end date.
4. Tenant terminates this agreement early in relation to section XVI (Damage to Premises).
5. An arbitrator, in relation to section XX (Disagreements During the Lease Period), orders the early termination of this agreement.
6. Both parties agree, in writing, to terminate this agreement early.

**XXIX. Severability** – If any court determines that any provision of this lease is invalid or unenforceable, any invalidity or unenforceability will affect only that provision. It will not make any other provision of this lease invalid or unenforceable, and shall be modified, amended, or limited only to the extent necessary to render it valid and enforceable.

### Signatures

**Landlord**

\_\_\_\_\_

Name:

Date:

**Tenant**

**COPY**

\_\_\_\_\_

Name: Brett Bray, Blanco County Judge

Date: 11-26-24

ENTITY NAME

Covered Applications and Prohibited  
Technology Policy

Date: September 16, 2024

Version: 1.0

# CONTENTS

Instructions for Governmental Entity .....	3
<b>1.0 Introduction.....</b>	<b>4</b>
1.1 Purpose.....	4
1.2 Scope.....	4
<b>2.0 Covered Applications.....</b>	<b>54</b>
2.1 Scope and Definitions .....	<del>54</del>
2.2 Covered Applications on Government-Owned or Leased Devices.....	5
2.3 Ongoing and Emerging Technology Threats.....	6
2.4 Bring Your Own Device Policy .....	6
2.5 Covered Application Exceptions.....	7
<b>3.0 Prohibited Technology Policy.....</b>	<b>7</b>
3.1 Scope.....	7
3.2 State Agency-Owned or -Leased Devices.....	8
3.3 Personal Devices Used For State Agency Business.....	8
3.4 Sensistive Locations.....	9
3.5 Network Restrictions.....	9
3.6 Prohibited Technologies Exceptions.....	<del>109</del>
3.7 Bring Your Own Device Policy for [Governmental Entity] Not Subject to Section 3.2 .....	10
3.8 Ongoing and Emerging Technology Threats Pursuant to the Governor's Directive.....	<del>11</del> <del>10</del>
<b>4.0 Policy Compliance.....</b>	<b>11</b>
<b>5.0 Policy Review.....</b>	<b>11</b>

## INSTRUCTIONS FOR GOVERNMENTAL ENTITY

This document is intended to serve as a model policy for Texas governmental entities to modify and adopt to fulfill the requirements of Government Code Chapter 620 and the Office of the Governor's directive regarding the installation and use of prohibited technologies on personal devices used to conduct state business. Entities should review this document and implement any organization-specific components as necessary. Sections in the policy **[contained in bold brackets]** are intended to be replaced by the entity implementing the policy.

Please direct questions regarding this model policy to [GRC@dir.texas.gov](mailto:GRC@dir.texas.gov).

LEAD

## 1.0 INTRODUCTION

---

### 1.1 PURPOSE

On December 7, 2022, Governor Greg Abbott required all state agencies to ban the video-sharing application TikTok from all state-owned and state-issued devices and networks over the Chinese Communist Party's ability to use the application for surveilling Texans. Governor Abbott also directed the Texas Department of Public Safety (DPS) and the Texas Department of Information Resources (DIR) to develop a plan providing state agencies guidance on managing personal devices used to conduct state business. Following the issuance of the Governor's directive, the 88<sup>th</sup> Texas Legislature passed [Senate Bill 1893](#), which prohibits the use of covered applications on governmental entity devices.

As required by the Governor's directive and Senate Bill 1893, this model policy establishes a template that entities subject to the directive or bill may mimic to prohibit the installation or use of covered applications or prohibited technologies on applicable devices.

### 1.2 SCOPE AND APPLICATION

Due to distinctions in requirements between the Governor's directive and SB 1893, Sections 2 and 3 apply to distinct organizations. Where appropriate, each section will identify the unique entities to whom the section applies and the appropriate definitions.

Governmental entities, including local governments, must adopt a covered applications policy as described by [Section 2.0](#).

State agencies to whom the Governor issued his December 7, 2022, directive must adopt a prohibited technology policy as described by [Section 3.0](#). To the extent a state agency is also subject to the requirements of Senate Bill 1893, that agency must also adopt a covered applications policy as described by [Section 2.0](#).

## 2.0 COVERED APPLICATIONS POLICY FOR GOVERNMENTAL ENTITIES

### 2.1 SCOPE AND DEFINITIONS

Pursuant to Senate Bill 1893, governmental entities, as defined below, must establish a covered applications policy:

- A department, commission, board, office, or other agency that is in the executive or legislative branch of state government and that was created by the constitution or a statute, including an institution of higher education as defined by Education Code Section 61.003.
- The supreme court, the court of criminal appeals, a court of appeals, a district court, or the Texas Judicial Council or another agency in the judicial branch of state government.
- A political subdivision of this state, including a municipality, county, or special purpose district.

This policy applies to all [Governmental Entity] full- and part-time employees, contractors, paid or unpaid interns, and other users of government networks. All [Governmental Entity] employees are responsible for complying with this policy.

A covered application is:

- The social media service TikTok or any successor application or service developed or provided by ByteDance Limited, or an entity owned by ByteDance Limited.
- A social media application or service specified by proclamation of the governor under Government Code Section 620.005.

### 2.2 COVERED APPLICATIONS ON GOVERNMENT-OWNED OR LEASED DEVICES

Except where approved exceptions apply, the use or installation of covered applications is prohibited on all government-owned or -leased devices, including cell phones, tablets, desktop and laptop computers, and other internet-capable devices.

**[Governmental Entity]** will identify, track, and manage all government-owned or -leased devices including mobile phones, tablets, laptops, desktop computers, or any other internet-capable devices to:

- a. Prohibit the installation of a covered application.
- b. Prohibit the use of a covered application.
- c. Remove a covered application from a government-owned or -leased device that was on the device prior to the passage of S.B. 1893 (88th Leg, R.S.).
- d. Remove an application from a government-owned or -leased device if the Governor issues a proclamation identifying it as a covered application.

**[Governmental Entity]** will manage all government-owned or leased mobile devices by implementing the security measures listed below:

- a. **[Restrict access to “app stores” or unauthorized software repositories to prevent the installation of unauthorized applications.]**
- b. **[Maintain the ability to remotely wipe non-compliant or compromised mobile devices.]**
- c. **[Maintain the ability to remotely uninstall unauthorized software from mobile devices.]**
- d. **[Other Governmental Entity-implemented security measures.]**

## 2.3 ONGOING AND EMERGING TECHNOLOGY THREATS

To provide protection against ongoing and emerging technological threats to the government’s sensitive information and critical infrastructure, DPS and DIR will regularly monitor and evaluate additional social media applications or services that pose a risk to this state.

DIR will annually submit to the Governor a list of social media applications and services identified as posing a risk to Texas. The Governor may proclaim items on this list as covered applications that are subject to this policy.

If the Governor identifies an item on the DIR-posted list described by this section, then **[Governmental Entity]** will remove and prohibit the covered application.

**[Governmental Entity]** may also prohibit social media applications or services in addition to those specified by proclamation of the Governor.

## 2.4 BRING YOUR OWN DEVICE POLICY

If **[Governmental Entity]** has a “Bring Your Own Device” (BYOD) program, then the

**[Governmental Entity]** may consider prohibiting the installation or operation of covered applications on employee-owned devices that are used to conduct government business.

## 2.5 COVERED APPLICATION EXCEPTIONS

**[Governmental Entity]** may permit exceptions authorizing the installation and use of a covered application on government-owned or -leased devices consistent with the authority provided by Government Code Chapter 620.

Government Code Section 620.004 only allows **[Governmental Entity]** to install and use a covered application on an applicable device to the extent necessary for:

- (1) Providing law enforcement; or
- (2) Developing or implementing information security measures.

If **[Governmental Entity]** authorizes an exception allowing for the installation and use of a covered application, **[Governmental Entity]** must use measures to mitigate the risks posed to the state during the application's use **[including:**

- **Measures that the Governmental Entity deems appropriate for its own policy.]**

**[Governmental Entity]** must document whichever measures it took to mitigate the risks posed to the state during the use of the covered application.

**[A Governmental Entity may include additional language within its policy as to which employees may install and use the covered application subject to its exception.]**

## 3.0 PROHIBITED TECHNOLOGY POLICY FOR STATE AGENCIES

---

### 3.1 SCOPE

This policy applies to all state agencies to whom the Governor issued his December 7, 2022, [directive](#). This policy applies to all **[Agency Name]** employees, including interns and apprentices, contractors, and users of state networks. All **[Agency Name]** employees, contractors, and state network users to whom this policy applies are responsible for complying with these requirements and prohibitions.



## 3.2 STATE AGENCY-OWNED DEVICES

Except where approved exceptions apply, the use or download of prohibited applications or websites is prohibited on all state-owned devices, including cell phones, tablets, desktop and laptop computers, and other internet capable devices.

The **[Agency Name]** must identify, track, and control state-owned devices to prohibit the installation of or access to all prohibited applications. This includes the various prohibited applications made available through application stores for mobile, desktop, or other internet capable devices.

The **[Agency Name]** must manage all state-owned mobile devices by implementing the security controls listed below:

- a. Restrict access to "app stores" or nonauthorized software repositories to prevent the install of unauthorized applications.
- b. Maintain the ability to remotely wipe noncompliant or compromised mobile devices.
- c. Maintain the ability to remotely uninstall unauthorized software from mobile devices.
- d. Deploy secure baseline configurations for mobile devices as determined by **[Agency Name]**.

## 3.3 PERSONAL DEVICES USED FOR STATE AGENCY BUSINESS

Employees and contractors may not install or operate prohibited applications or technologies on any personal device that is used to conduct state business, which includes using the device to access any state-owned data, applications, email accounts, non-public facing communications, state email, VoIP, SMS, video conferencing, CAPPs, Texas.gov, and any other state databases or applications.

A state agency that authorizes its employees and contractors to use their personal devices to conduct state business must also establish a "Bring Your Own Device" (BYOD) program. If an employee or contractor has a justifiable need to allow the use of personal devices to conduct state business, the employee or contractor must ensure that their device complies with **[State Agency's]** BYOD program, which may include proactive enrollment in the program.

**[State Agency's]** BYOD program prohibits an employee or contractor from enabling prohibited technologies on personal devices enrolled in the **[State Agency]** program.

### 3.4 SENSITIVE LOCATIONS

[State Agency] identify, catalogue, and label all sensitive locations. A sensitive location is any location, physical or logical (such as video conferencing, or electronic meeting rooms), that is used to discuss confidential or sensitive information including information technology configurations, criminal justice information, financial data, personally identifiable data, sensitive personal information, or any data protected by federal or state law.

An employee whose personal device, including their personal cell phone, tablet, or laptop, is not compliant with this prohibited technology policy may not bring their personal device into sensitive locations. This includes using their unauthorized personal device to access any electronic meeting labeled as a sensitive location.

Visitors granted access to sensitive locations are subject to the same limitations as employees and contractors. If a visitor is granted access to a sensitive location and their personal device has a prohibited application installed on it, then the visitor must leave their unauthorized personal device at an appropriate location that is not identified as sensitive.

### 3.5 NETWORK RESTRICTIONS

DIR has blocked access to prohibited technologies on the state network. To ensure multiple layers of protection, [State Agency] has also implemented additional network-based restrictions, which include:

- a. Configuring agency firewalls to block access to statewide prohibited services on all agency technology infrastructures, including local networks, WAN, and VPN connections.
- b. Prohibiting personal devices with prohibited technologies installed from connecting to agency or state technology infrastructure or state data.
- c. With the [State Agency] executive head's approval, providing a separate network that allows access to prohibited technologies with the approval of the executive head of the agency.
- d. **[Additional Measures that the State Agency deems appropriate for its own policy.]**

### 3.6 PROHIBITED TECHNOLOGIES EXCEPTIONS

Only the [State Agency] executive may approve exceptions to the ban on prohibited technologies. This authority may not be delegated. All approved exceptions to applications, software, or hardware included on the prohibited technology list must be reported to DIR.

Exceptions to the prohibited technology policy must only be considered when:

- the use of prohibited technologies is required for a specific business need, such as enabling criminal or civil investigations; or
- for sharing of information to the public during an emergency.

For personal devices used for state business, exceptions should be limited to extenuating circumstances and only granted for a predefined period of time. To the extent practicable or possible, exception-based use should only be performed on devices that are not used for other state business and on non-state networks, and the user should disable cameras and microphones on devices authorized for exception-based use.

### 3.7 BRING YOUR OWN DEVICE POLICY FOR A GOVERNMENTAL ENTITY NOT SUBJECT TO THE GOVERNOR'S PROHIBITED TECHNOLOGY DIRECTIVE

If a Governmental Entity is not subject to the Governor's prohibited technology directive but is subject to Senate Bill 1893, it may also consider prohibiting the installation or operation of prohibited technologies and covered applications on employee-owned devices that are used to conduct government business.

If [Governmental Entity] has a "Bring Your Own Device" (BYOD) program, then the [Governmental Entity] shall institute a "Bring Your Own Device" (BYOD) policy requiring the enrollment of these personal devices in the entity's program before their continued use in conducting governmental business.

### 3.8 ONGOING AND EMERGING TECHNOLOGY THREATS PURSUANT TO THE GOVERNOR'S DIRECTIVE

To provide protection against ongoing and emerging technological threats to the state's sensitive information and critical infrastructure, DPS and DIR will regularly monitor and evaluate additional technologies posing concerns for inclusion in this policy.

DIR posts the list of all prohibited technologies, including applications, software, hardware, or technology providers, to its website. If, after consultation between DIR and DPS, a new technology must be added to this list, DIR will update the prohibited technology list posted on its website.

[**State Agency**] will implement the removal and prohibition of any listed technology on all applicable devices. [**State Agency**] may prohibit other technology threats in addition to those on the posted list should [**State Agency**] determine that such prohibition is appropriate.

### 4.0 POLICY COMPLIANCE

---

All [**State Agency**] employees shall sign a document annually confirming their understanding of the agency's covered applications and prohibited technology policies. Governmental entities that are subject to Senate Bill 1893 but not subject to the Governor's December 07, 2022, directive may elect not to require employees to complete an annual certification.

[**Governmental Entity**] will verify compliance with this policy through various methods, including but not limited to, IT/security system reports and feedback to leadership.

An employee found to have violated this policy may be subject to disciplinary action, including termination of employment.

### 5.0 POLICY REVIEW

---

This policy will be reviewed [**entity-defined frequency**] and updated as necessary to reflect changes in state law, additions to applications identified under Government Code Section 620.006, updates to the prohibited technology list posted to DIR's website, or to suit the needs of [**Governmental Entity**]



## Your quote is ready for purchase.

Complete the purchase of your personalized quote through our secure online checkout before the quote expires on **Dec. 04, 2024**.

You can download a copy of this quote during checkout.

**Place your order**

<b>Quote No.</b>	3000183347775.1	<b>Sales Rep</b>	Samantha Currey
<b>Total</b>	\$8,004.14	<b>Phone</b>	1(800) 456-3355, 6183009
<b>Customer #</b>	2242137	<b>Email</b>	Samantha_Currey@Dell.com
<b>Quoted On</b>	Nov. 15, 2024	<b>Billing To</b>	ACCOUNTS PAYABLE
<b>Expires by</b>	Dec. 04, 2024		BLANCO COUNTY SHERIFF'S
	Texas Department of		DEPT
<b>Contract Name</b>	Information Resources (TX		400 S US HWY 281
	DIR)		JOHNSON CITY, TX 78636-4647
<b>Contract Code</b>	C000000006841		
<b>Customer Agreement #</b>	TX DIR-TSO-3763		
<b>Deal ID</b>	28474970		

### Message from your Sales Rep

Thank you for contacting me about your tech needs! It's been a pleasure to work with you and your business. Please review All details (shipping and billing addresses, configuration, timeframe, etc...) of this quote before placing your order. By clicking "order now" within your premier portal, you agree that the information in this quote is accurate and that you agree to Dell's commercial terms of sale (at the bottom of each page on Dell.com). All returned orders are subject to a 15% restocking fee. Thank you!

Regards,  
Samantha Currey

### Additional Comments

Due to the increasing demands causing ongoing shortages, our pricing industry wide has been modified. Pricing for our products have gone up this quarter and moving forward for the upcoming year. Lead times are also increasing daily, so we strongly urge you to place any upcoming orders as soon as you can. I am happy to price match, but please know I do my best to deliver the best service and solution for my customers. Please rest assured that as our valued customer, you have received the best possible value for this quote. Once this quote expires, pricing will increase due to demand, inventory, shortages and moving products. Renewing expired quotes delays re-approving discounts and promotions are also subject to expire once the quote has been expired. Again, please let me know how you would like to proceed and once you approve quote, you can click "order now," button. I'm happy to give you a call to give you the breakdown of anything else related. Thanks so much for your business and patience! Sincerely, Samantha Currey (512) 720-4664

---

## Shipping Group

### Shipping To

ACCOUNTS PAYABLE  
BLANCO COUNTY SHERIFF'S DEPT  
400 S US HWY 281  
JOHNSON CITY, TX 78636-4647  
(210) 868-7104

### Shipping Method

Standard Delivery

Product	Unit Price	Quantity	Subtotal
OptiPlex Tower (Plus 7020)	\$972.64	4	\$3,890.56
Dell 24 Monitor - P2425H	\$133.39	4	\$533.56
Dell Latitude 5550	\$1,105.69	2	\$2,211.38
OptiPlex All-in-One (7420)	\$1,368.64	1	\$1,368.64

---

Subtotal:	\$8,004.14
Shipping:	\$0.00
Non-Taxable Amount:	\$8,004.14
Taxable Amount:	\$0.00
Estimated Tax:	\$0.00

---

**Total:** \$8,004.14

Special pricing may be available for qualified customers. Please contact your DFS Sales Representative for details.



Accelerate the power  
of AI for your data

Take the first step in achieving  
Generative AI success

[Learn More](#)

## Shipping Group Details

### Shipping To

ACCOUNTS PAYABLE  
 BLANCO COUNTY SHERIFF'S DEPT  
 400 S US HWY 281  
 JOHNSON CITY, TX 78636-4647  
 (210) 868-7104

### Shipping Method

Standard Delivery

### OptiPlex Tower (Plus 7020)

Estimated delivery if purchased today:

Nov. 26, 2024

Contract # C000000006841

Customer Agreement # TX DIR-TSO-3763

Unit Price	Quantity	Subtotal
\$972.64	4	\$3,890.56

Description	SKU	Unit Price	Quantity	Subtotal
OptiPlex Tower Plus 7020 XCTO	210-BLDN	-	4	-
Intel Core i5 processor 14600 vPro (24MB cache, 14 cores, 20 threads, up to 5.2 GHz Turbo, 65W)	338-CNCJ	-	4	-
Windows 11 Pro, English, Brazilian Portuguese PT-BR, French, Spanish	619-ARSB	-	4	-
Activate Your Microsoft 365 For A 30 Day Trial	658-BCSB	-	4	-
CrowdStrike Endpoint Protection Pro w Essential Support 1yr	634-CCLG	-	4	-
8 GB: 1 x 8 GB, DDR5	370-BBQH	-	4	-
M.2 2230 256GB PCIe NVMe SSD Class 35	400-BQSD	-	4	-
M2X3.5 Screw for SSD/DDPE	773-BBBC	-	4	-
NO RAID	817-BBBN	-	4	-
Intel Integrated Graphics	490-BBFG	-	4	-
OptiPlex Tower Plus with 260W Bronze Power Supply	329-BJYQ	-	4	-
System Power Cord (Philippine/TH/US)	450-AAOJ	-	4	-
No Optical Disk Drive	429-ABIV	-	4	-
CMS Software not included	632-BBBJ	-	4	-
No Media Card Reader	379-BBHM	-	4	-
Intel(R) AX211 Wi-Fi 6E 2x2 and Bluetooth	555-BHDU	-	4	-
External Antenna	555-BHDY	-	4	-
Wireless Driver, Intel Wi-Fi 6E AX211 2x2 and Bluetooth wireless card	555-BKNB	-	4	-
No Additional Video Ports	492-BCKH	-	4	-
Dell Pro Wireless Keyboard and Mouse - KM5221W - English - Black	580-AJJG	-	4	-
Mouse included with Keyboard	570-AADI	-	4	-
No Cover Selected	325-BCZQ	-	4	-
Dell Additional Software	634-CHFP	-	4	-
ENERGY STAR Qualified	387-BBLW	-	4	-
SERI Guide (ENG/FR/Multi)	340-AGIK	-	4	-
Watch Dog SRV	379-BFMR	-	4	-
Quick Start Guide, OptiPlex Tower Plus	340-DMRT	-	4	-

Print on Demand Label	389-BDQH	-	4	-
Trusted Platform Module (Discrete TPM Enabled)	329-BBJL	-	4	-
Shipping Material	340-CNZU	-	4	-
Shipping Label	389-BBUU	-	4	-
Regulatory Label for OptiPlex Tower Plus 7020 260W PSU	389-FGLS	-	4	-
No Hard Drive Bracket, Dell OptiPlex	575-BBKX	-	4	-
Intel® Rapid Storage Technology Driver	658-BFSK	-	4	-
Intel Core i5 Processor Label	340-CUEW	-	4	-
Desktop BTO Standard shipment	800-BBIO	-	4	-
Intel Ethernet Network Adapter I226 Series	385-BBTG	-	4	-
No Additional Add In Cards	382-BBHx	-	4	-
Custom Configuration	817-BBBB	-	4	-
No vPro support	631-BBRD	-	4	-
Internal Speaker	520-AARD	-	4	-
EPEAT 2018 Registered (Silver)	379-BDTo	-	4	-
Dell Limited Hardware Warranty Plus Service	812-3886	-	4	-
ProSupport: 7x24 Technical Support, 3 Years	812-3894	-	4	-
ProSupport: Next Business Day Onsite 3 Years	812-3908	-	4	-
Thank you choosing Dell ProSupport. For tech support, visit <a href="https://support.dell.com/ProSupport">//support.dell.com/ProSupport</a>	989-3449	-	4	-
		<b>Unit Price</b>	<b>Quantity</b>	<b>Subtotal</b>
		<b>\$133.39</b>	<b>4</b>	<b>\$533.56</b>

**Dell 24 Monitor - P2425H**

Estimated delivery if purchased today:  
Nov. 21, 2024  
Contract # C000000006841  
Customer Agreement # TX DIR-TSO-3763

Description	SKU	Unit Price	Quantity	Subtotal
Dell 24 Monitor - P2425H	210-BMGH	-	4	-
Dell Limited Hardware Warranty	814-5380	-	4	-
Advanced Exchange Service, 3 Years	814-5381	-	4	-

**Dell Latitude 5550**

Estimated delivery if purchased today:  
Nov. 21, 2024  
Contract # C000000006841  
Customer Agreement # TX DIR-TSO-3763

Description	SKU	Unit Price	Quantity	Subtotal
Dell Latitude 5550 BTX Base	210-BLMN	-	2	-
Intel Core Ultra 5 125U processor (12 MB cache, 12 cores, 14 threads, up to 4.3 GHz Turbo)	379-BFNZ	-	2	-
Windows 11 Pro, English, Brazilian Portuguese PT-BR, French, Spanish	619-ARSB	-	2	-
Activate Your Microsoft 365 For A 30 Day Trial	658-BCSB	-	2	-
Assembly Base MTL 5550	338-CNRG	-	2	-
Integrated Intel graphics for Intel Core Ultra 5 125U processor	338-CNRK	-	2	-
Latitude 5550 Bottom Door, MTL U15	321-BKTQ	-	2	-
Intel Rapid Storage Technology Driver	409-BCXY	-	2	-
		<b>Unit Price</b>	<b>Quantity</b>	<b>Subtotal</b>
		<b>\$1,105.69</b>	<b>2</b>	<b>\$2,211.38</b>



Intel vPro Management Disabled	631-BBSQ	-	2	-
16 GB: 2 x 8 GB, DDR5, 5600 MT/s (5200 MT/s with 13th Gen Intel Core processors)	370-BBTL	-	2	-
256 GB, M.2 2230, TLC, Gen 4 PCIe NVMe, SSD	400-BRFT	-	2	-
15.6", FHD 1920x1080, 60Hz, IPS, Touch, AG, 250 nit, 45% NTSC, FHD+IR Cam, 4G	391-BJGT	-	2	-
English US backlit AI hotkey keyboard with numeric keypad, 99-key	583-BLNH	-	2	-
Intel AX211 WLAN Driver	555-BKQC	-	2	-
Intel Wi-Fi 6E (6 where 6E unavailable) AX211, 2x2, 802.11ax, Bluetooth 5.3 wireless card	555-BKLQ	-	2	-
3-cell, 54 Wh, ExpressCharge Capable, ExpressCharge Boost Capable	451-BDGX	-	2	-
65W AC adapter, USB Type-C, EcoDesign	492-BDMN	-	2	-
No Security	346-BKLV	-	2	-
Foxit PDF Editor with AI Assistant	634-CLHT	-	2	-
E4 Power Cord 1M for US	537-BBDO	-	2	-
Latitude 5550 Quick Start Guide	340-DMNY	-	2	-
SERI Guide (ENG/FR/Multi)	340-AGIK	-	2	-
ENERGY STAR Qualified	387-BBPC	-	2	-
Fixed Hardware Configuration	998-GXFR	-	2	-
Dell Additional Software	658-BFQB	-	2	-
BTS MTL 65W ADPT	340-DMLZ	-	2	-
Intel Core Ultra 5 Non-vPro Label	389-FGSN	-	2	-
POD Label	389-EDJB	-	2	-
FHD HDR IR Camera, ExpressSign-In, No Intelligent Privacy, TNR, Camera Shutter, Microphone	319-BBKH	-	2	-
EPEAT 2018 Registered (Gold)	379-BDZB	-	2	-
Dell Limited Hardware Warranty Extended Year(s)	975-3461	-	2	-
Dell Limited Hardware Warranty	997-8317	-	2	-
ProSupport Plus: Next Business Day Onsite, 1 Year	997-8366	-	2	-
Thank you for choosing Dell ProSupport Plus. For tech support, visit <a href="http://www.dell.com/contactdell">www.dell.com/contactdell</a> or call 1-866-516-3115	997-8367	-	2	-
ProSupport Plus: 7x24 Technical Support, 3 Years	997-8380	-	2	-
ProSupport Plus: Next Business Day Onsite, 2 Year Extended	997-8381	-	2	-
ProSupport Plus: Keep Your Hard Drive, 3 Years	997-8382	-	2	-
ProSupport Plus: Accidental Damage Service, 3 Years	997-8383	-	2	-
		<b>Unit Price</b>	<b>Quantity</b>	<b>Subtotal</b>
		<b>\$1,368.64</b>	<b>1</b>	<b>\$1,368.64</b>

### OptiPlex All-in-One (7420)

Estimated delivery if purchased today:

Nov. 26, 2024

Contract # C000000006841

Customer Agreement # TX DIR-TSO-3763

Description	SKU	Unit Price	Quantity	Subtotal
Intel Core i7 processor 14700 vPro (33 MB cache, 20 cores, 28 threads, up to 5.4 GHz Turbo, 65W)	338-CNCK	-	1	-
Windows 11 Pro, English, Brazilian Portuguese PT-BR, French, Spanish	619-ARSB	-	1	-

16GB DDR5 Memory,1X16GB,Non-ECC,SoDIMM	370-BBPX	-	1	-
M.2 2230 256GB PCIe NVMe Class 35 Solid State Drive	400-BQTS	-	1	-
Thermal Pad, Screw and Rubber for SSD	412-ABEK	-	1	-
Intel Integrated Graphics	490-BBFG	-	1	-
Intel(R) AX211 Wi-Fi 6E 2x2 and Bluetooth	555-BH DU	-	1	-
Screw for WLAN card	555-BIGS	-	1	-
Wireless Driver, Intel AX211 Wi-Fi 6E 2x2 (6GHz), BT 5.3	555-BKJC	-	1	-
OptiPlex All-in-One 7420, 65W CPU, Touch, FHD HDR camera, UMA, 160W Bronze	329-BJYP	-	1	-
Dell Pro Wireless Keyboard and Mouse - KM5221W - English - Black	580-AJJG	-	1	-
Mouse included with Keyboard	570-AADI	-	1	-
No Cover Selected	325-BCZQ	-	1	-
Height Adjustable Stand for OptiPlex All-in-One	575-BCNS	-	1	-
Dell Additional Software	634-CHFP	-	1	-
ENERGY STAR Qualified	387-BBLW	-	1	-
System Power Cord (Philippine/TH/US)	450-AAOJ	-	1	-
SERI Guide (ENG/FR/Multi)	340-AGIK	-	1	-
Watch Dog SRV	379-BFMR	-	1	-
Quick Start Guide, OptiPlex All-in-One 65W	340-DMGZ	-	1	-
Trusted Platform Module (Discrete TPM Enabled)	329-BBJL	-	1	-
Package for Fixed/ HAS/ no stand (DAO, CCC)	340-DDGK	-	1	-
DAO factory Information	340-DFWR	-	1	-
Shipping Label	389-BBUU	-	1	-
Regulatory Label for OptiPlex All-in-One 7420 65W, 160W Bronze, DAO/BCC	389-FGRQ	-	1	-
SW Driver, Intel Rapid Storage Technology, OptiPlex All-in-One	658-BFST	-	1	-
Intel Core i7 vPro Enterprise Processor Label	389-EDDR	-	1	-
Desktop BTO Standard shipment	800-BBIO	-	1	-
Custom Configuration	817-BBBB	-	1	-
OptiPlex All-in-One 7420 65W XCTO	210-BLDW	-	1	-
OptiPlex All-in-One Touch Panel	391-BDPU	-	1	-
EPEAT 2018 Registered (Silver)	379-BD TO	-	1	-
Intel vPro Enterprise	631-BBPZ	-	1	-
Dell Limited Hardware Warranty Plus Service	867-5596	-	1	-
ProSupport Plus: Accidental Damage Service, 3 Years	867-5686	-	1	-
ProSupport Plus: Keep Your Hard Drive, 3 Years	867-5698	-	1	-
ProSupport Plus: Next Business Day Onsite, 3 Years	867-5710	-	1	-
ProSupport Plus: 7x24 Technical Support, 3 Years	867-5722	-	1	-
Thank you for choosing Dell ProSupport Plus. For tech support, visit <a href="http://www.dell.com/contactdell">www.dell.com/contactdell</a> or call 1-866-516-3115	997-8367	-	1	-
Activate Your Microsoft 365 For A 30 Day Trial	658-BCSB	-	1	-
CrowdStrike Endpoint Protection Pro w Essential Support 1yr	634-CCLG	-	1	-

<b>Subtotal:</b>	<b>\$8,004.14</b>
<b>Shipping:</b>	<b>\$0.00</b>
<b>Estimated Tax:</b>	<b>\$0.00</b>
<hr/>	
<b>Total:</b>	<b>\$8,004.14</b>

## Important Notes

---

### Terms of Sale

This Quote will, if Customer issues a purchase order for the quoted items that is accepted by Supplier, constitute a contract between the entity issuing this Quote ("Supplier") and the entity to whom this Quote was issued ("Customer"). Unless otherwise stated herein, pricing is valid for thirty days from the date of this Quote. All product, pricing and other information is based on the latest information available and is subject to change. Supplier reserves the right to cancel this Quote and Customer purchase orders arising from pricing errors. Taxes and/or freight charges listed on this Quote are only estimates. The final amounts shall be stated on the relevant invoice. Additional freight charges will be applied if Customer requests expedited shipping. Please indicate any tax exemption status on your purchase order and send your tax exemption certificate to Tax\_Department@dell.com or ARSalesTax@emc.com, as applicable.

**Governing Terms:** This Quote is subject to: (a) a separate written agreement between Customer or Customer's affiliate and Supplier or a Supplier's affiliate to the extent that it expressly applies to the products and/or services in this Quote or, to the extent there is no such agreement, to the applicable set of Dell's Terms of Sale (available at [www.dell.com/terms](http://www.dell.com/terms) or [www.dell.com/oemterms](http://www.dell.com/oemterms)), or for cloud/as-a-Service offerings, the applicable cloud terms of service (identified on the Offer Specific Terms referenced below); and (b) the terms referenced herein (collectively, the "Governing Terms"). Different Governing Terms may apply to different products and services on this Quote. The Governing Terms apply to the exclusion of all terms and conditions incorporated in or referred to in any documentation submitted by Customer to Supplier.

**Supplier Software Licenses and Services Descriptions:** Customer's use of any Supplier software is subject to the license terms accompanying the software, or in the absence of accompanying terms, the applicable terms posted on [www.Dell.com/eula](http://www.Dell.com/eula). Descriptions and terms for Supplier-branded standard services are stated at [www.dell.com/servicecontracts/global](http://www.dell.com/servicecontracts/global) or for certain infrastructure products at [www.dell.com/en-us/customer-services/product-warranty-and-service-descriptions.htm](http://www.dell.com/en-us/customer-services/product-warranty-and-service-descriptions.htm).

**Offer-Specific, Third Party and Program Specific Terms:** Customer's use of third-party software is subject to the license terms that accompany the software. Certain Supplier-branded and third-party products and services listed on this Quote are subject to additional, specific terms stated on [www.dell.com/offeringspecificterms](http://www.dell.com/offeringspecificterms) ("Offer Specific Terms").

**In case of Resale only:** Should Customer procure any products or services for resale, whether on standalone basis or as part of a solution, Customer shall include the applicable software license terms, services terms, and/or offer-specific terms in a written agreement with the end-user and provide written evidence of doing so upon receipt of request from Supplier.

**In case of Financing only:** If Customer intends to enter into a financing arrangement ("Financing Agreement") for the products and/or services on this Quote with Dell Financial Services LLC or other funding source pre-approved by Supplier ("FS"), Customer may issue its purchase order to Supplier or to FS. If issued to FS, Supplier will fulfill and invoice FS upon confirmation that: (a) FS intends to enter into a Financing Agreement with Customer for this order; and (b) FS agrees to procure these items from Supplier. Notwithstanding the Financing Agreement, Customer's use (and Customer's resale of and the end-user's use) of these items in the order is subject to the applicable governing agreement between Customer and Supplier, except that title shall transfer from Supplier to FS instead of to Customer. If FS notifies Supplier after shipment that Customer is no longer pursuing a Financing Agreement for these items, or if Customer fails to enter into such Financing Agreement within 120 days after shipment by Supplier, Customer shall promptly pay the Supplier invoice amounts directly to Supplier.

Customer represents that this transaction does not involve: (a) use of U.S. Government funds; (b) use by or resale to the U.S. Government; or (c) maintenance and support of the product(s) listed in this document within classified spaces. Customer further represents that this transaction does not require Supplier's compliance with any statute, regulation or information technology standard applicable to a U.S. Government procurement.

For certain products shipped to end users in California, a State Environmental Fee will be applied to Customer's invoice. Supplier encourages customers to dispose of electronic equipment properly.

Electronically linked terms and descriptions are available in hard copy upon request.

**^DELL BUSINESS CREDIT (DBC):** Offered to business customers by WebBank, who determines qualifications for and terms of credit. Taxes, shipping and other charges are extra and vary. The Total Minimum Payment Due is the greater of either \$20 or 3% of the New Balance shown on the statement rounded up to the next dollar, plus all past due amounts. Dell and the Dell logo are trademarks of Dell Inc.

# GTS

## TECHNOLOGY SOLUTIONS

GTS Technology Solutions, Inc.  
 9211 Waterford Centre Blvd Suite 275  
 Austin, Texas 78758  
 Phone: 512.452.0651

# QUOTE

Quote Number: **Q-08694**  
 Quoted Date: 11/07/2024  
 Expiration Date: 12/12/2024  
 Account Exec: Ashley Ambroso  
 Inside Sales Rep: Jed Rhodes  
 jed.rhodes@gts-ts.com  
 (512) 681-6219  
 NET 30

Terms:

### QUOTE FOR

Blanco County

LINE	ITEM	DESCRIPTION	SPECIFICATIONS	CONTRACT	QTY	PRICE	EXTENDED PRICE
------	------	-------------	----------------	----------	-----	-------	----------------

1	FZ-40EZ-0BBM	Panasonic TOUGHBOOK 14" FZ-40 Touchscreen Rugged Notebook, Full HD, Intel Core Ultra 5 135H, 16 GB, 512 GB SSD		DIR-CPO-5225	4	\$ 4,200.00	\$ 16,800.00
2	FZ-VNF402MIS	Panasonic Pre-installed Contactless Smart Card xPAK for FZ-40 Mk1 Palm Rest Expansion Area (ISO 14443/15693/18092)		DIR-CPO-5225	4	\$ 150.33	\$ 601.32
3	CF-SVCLTNFY4	PROTECTION PLUS WARRANTY - LAPTOP (YEAR 4) Must be purchased at time of sale.		DIR-CPO-5225	4	\$ 191.71	\$ 766.84

### Optional

LINE	ITEM	DESCRIPTION	SPECIFICATIONS	CONTRACT	QTY	PRICE	EXTENDED PRICE
------	------	-------------	----------------	----------	-----	-------	----------------

4	FZ-VBR401MIS	Panasonic Pre-installed Barcode xPAK (1D/2D capable) for FZ-40 Mk1 Left Expansion Area.		DIR-CPO-5225	4	\$ 612.15	\$ 2,448.60
---	--------------	---	--	--------------	---	-----------	-------------

# GTS

TECHNOLOGY SOLUTIONS

# QUOTE

Quote Number:

Q-08694

Features trigger button.

Prices do NOT include taxes, insurance, shipping, delivery, setup fees, or any cables or cabling services or material unless specifically listed above. If a customer requests expedited or special delivery, causes carrier delays or requests redelivery, customer will be responsible for any additional charges for these services directly billed by the carrier. All prices are subject to change without notice. Supply subject to availability. Dell maintains a strict zero-return policy. Therefore, purchases of incorrect quantity, specifications, items, or configurations are non-refundable and non-returnable. Please ensure that you have reviewed your quote thoroughly.

\*\*This quote does not include the applicable sales tax for our commercial customers\*\*

<b>Sales Total:</b>	<b>\$ 20,616.76</b>
<b>Freight &amp; Misc:</b>	<b>\$ 0.00</b>
<b>Tax Total:</b>	<b>\$ 0.00</b>
<b>Total (USD):</b>	<b>\$ 20,616.76</b>



# Investment Proposal (Quote)

RDO Equipment Co.  
 17301 IH-35 Ste 200  
 Buda TX, 78610  
 Phone: (737) 770-5100 - Fax:

Proposal for:  
 BLANCO COUNTY - A/P  
 PO BOX 471  
 JOHNSON CITY, TX, 786360471

Investment Proposal Date: 11/8/2024  
 Pricing Valid Until: 11/22/2024  
 Deal Number: 1835530  
 Customer Account#: 8880782  
 Sales Professional: Peter Arcos  
 Phone: (830) 632-3145  
 Fax:  
 Email: [parcos@rdoequipment.com](mailto:parcos@rdoequipment.com)

## Equipment Information

Quantity	Serial Number Stock Number	Hours (approx.)	Status / Year / Make / Model Additional Items	Cash Price
1	1DW544PAAPLZ17736 X709769	3012	New 2023 JOHN DEERE 544P  Warranty -John Deere Power Train & Hyd.-4000 Hours,Deductible: 0, Exp Date: 2/14/2026	\$164,850.00  \$0.00
1	J000155023-1 X732308	0	New 2022 JRB 544K3.0C	\$5,652.58
<b>Equipment Subtotal:</b>				<b>\$170,502.58</b>

## Trade Information

Serial Number	Year / Make / Model	Payoff Information	Trade In Hours	Trade In Value
11016T	0 JOHN DEERE 570A	\$0.00	0	(\$7,500.00)
3TJ00195	1993 CAT 918F	\$0.00	9000	(\$10,000.00)
<b>Total Trade in Value:</b>				<b>(\$17,500.00)</b>
<b>Trade Balance Owed:</b>				<b>\$0.00</b>
<b>Net Difference:</b>				<b>(\$17,500.00)</b>

## Purchase Order Totals

<b>Balance:</b>	\$153,002.58
<b>Total Taxable Amount:</b>	\$0.00
<b>TX STATE TAX:</b>	\$0.00
<b>TX COUNTY TAX:</b>	\$0.00
<b>TX SPECIAL TAX:</b>	\$0.00
<b>Sales Tax Total:</b>	\$0.00
<b>HEI:</b>	\$295.99
<b>TERP:</b>	\$2,295.04
<b>Sub Total:</b>	\$155,593.61
<b>Cash with Order:</b>	\$0.00
<b>Balance Due:</b>	<b>\$155,593.61</b>

## Equipment Options

Qty	Serial Number	Year / Make / Model	Description
1	1DW544PAAPLZ17736	2023 JOHN DEERE 544P	None
1	J000155023-1	2022 JRB 544K3.0C	None

# 544 P

Wheel Loader



JOHN DEERE





# ABOVE AND BEYOND

## MEET THE P-TIER WHEEL LOADERS



**SMARTWEIGH™  
PAYLOAD-WEIGHING  
SOLUTION IS DEERE  
DESIGNED & SUPPORTED**

When your material-handling application needs a heavy-duty lift, add a P-Tier Wheel Loader to your lineup. Combining convenient front-end features with near-parallel lift, spacious operator stations including customizable ergonomic electrohydraulic (EH) controls, streamlined electrical and hydraulic routing, and innovative options, these versatile and productive mid-size models are designed to help you take your operation to the next level.

### Take control

Operators can easily control up to six functions without letting go of the ergonomically designed joystick. Two industry-exclusive multifunction buttons can each be programmed to handle any of up to 10 functions selected through the monitor, including bucket vibrate and EH Precision mode.

### On your side

All daily service points including fuel refill are conveniently grouped at ground level on the left side of the machine for easy access. Routing of electrical wire harnesses and hydraulic hoses has been streamlined.

### Level up

AutoLevel enables near-perfect parallelism throughout the boom-raise-and-lower cycle, letting operators set their desired attachment angle to within  $\pm$  two degrees.

### At the forefront

Featuring bucket and linkage designs that improve load leveling, material retention, and visibility, P-Tier Loaders yield more productivity and performance than previous models. Enhanced-performance buckets with integrated spill guards, curved side cutters, and impressive rollback deliver elevated bucket-fill performance and material retention compared to earlier offerings.

### Material matters

SmartWeigh option features dynamic weighing technology that allows operators to weigh without interrupting workflow and removes the need to lower and raise the boom after tipoff. Shared through the onboard monitor, SmartWeigh is easy to calibrate and effortlessly integrates with the John Deere Operations Center™ so you can track and visualize payload data from almost anywhere. Available as a factory-installed or field-kit option, you can also try SmartWeigh at a low cost for 250 machine hours.



**544 P**

**WHEEL LOADER**

**3" MORE LEGROOM**  
THAN K-SERIES CABS



# 544 P-TIER WHEEL LOADER SPECIFICATIONS

# 544

# P

While general information, pictures, and descriptions are provided, some illustrations and text may include product options and accessories NOT AVAILABLE in all regions, and in some countries products and accessories may require modifications or additions to ensure compliance with the local regulations of those countries.

## Hydraulic System/Steering (continued) 544 P-TIER Z-BAR / HIGH-LIFT / HIGH-LIFT PLUS

Hydraulic Cycle Times	Z-Bar / High-Lift / High-Lift Plus
Raise	5.5 sec.
Dump	2.2 sec.
Lower (power down)	3.5 sec.
Total	11.2 sec.

## Bucket Capacity Range

Bucket Type	
Pin-On	2.1–2.5 m <sup>3</sup> (2.75–3.25 cu. yd.)
Coupler	1.9–4.0 m <sup>3</sup> (2.5–5.25 cu. yd.)

## Dimensions and Specifications With Pin-On Bucket With Bolt-On Edge

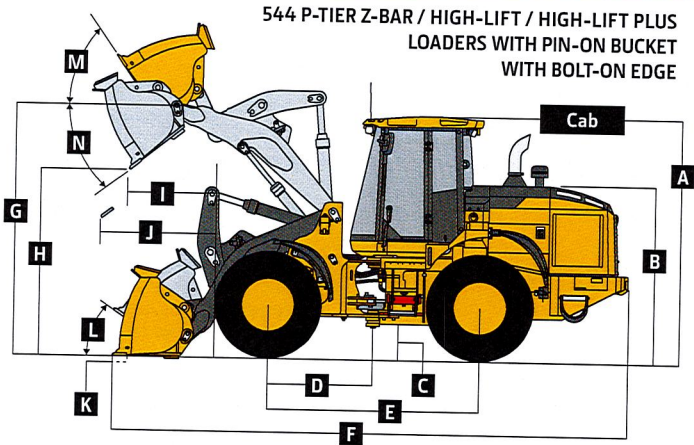

544 P-TIER Z-BAR / HIGH-LIFT / HIGH-LIFT PLUS LOADERS WITH PIN-ON BUCKET WITH BOLT-ON EDGE

	Z-Bar 2.3-m <sup>3</sup> (3.0 cu. yd.) enhanced performance	Z-Bar 2.5-m <sup>3</sup> (3.25 cu. yd.) enhanced performance	High-Lift 2.1-m <sup>3</sup> (2.75 cu. yd.) enhanced performance	High-Lift 2.3-m <sup>3</sup> (3.0 cu. yd.) enhanced performance	High-Lift Plus 2.1-m <sup>3</sup> (2.75 cu. yd.) enhanced performance	High-Lift Plus 2.3-m <sup>3</sup> (3.0 cu. yd.) enhanced performance
<b>Dimensions With Bucket With Bolt-On Edge (illustration above right)</b>						
A Height to Top of Cab	3.33 m (10 ft. 11 in.)	3.33 m (10 ft. 11 in.)	3.33 m (10 ft. 11 in.)	3.33 m (10 ft. 11 in.)	3.33 m (10 ft. 11 in.)	3.33 m (10 ft. 11 in.)
B Hood Height	2.375 m (7 ft. 9 in.)	2.375 m (7 ft. 9 in.)	2.375 m (7 ft. 9 in.)	2.375 m (7 ft. 9 in.)	2.375 m (7 ft. 9 in.)	2.375 m (7 ft. 9 in.)
C Ground Clearance	0.40 m (15.7 in.)	0.40 m (15.7 in.)	0.40 m (15.7 in.)	0.40 m (15.7 in.)	0.40 m (15.7 in.)	0.40 m (15.7 in.)
D Length From Centerline to Front Axle	1.45 m (4 ft. 9 in.)	1.45 m (4 ft. 9 in.)	1.45 m (4 ft. 9 in.)	1.45 m (4 ft. 9 in.)	1.45 m (4 ft. 9 in.)	1.45 m (4 ft. 9 in.)
E Wheelbase	2.93 m (9 ft. 7 in.)	2.93 m (9 ft. 7 in.)	2.93 m (9 ft. 7 in.)	2.93 m (9 ft. 7 in.)	2.93 m (9 ft. 7 in.)	2.93 m (9 ft. 7 in.)
F Overall Length, Bucket on Ground	7.49 m (24 ft. 7 in.)	7.49 m (24 ft. 7 in.)	7.80 m (25 ft. 7 in.)	7.88 m (25 ft. 10 in.)	8.17 m (26 ft. 10 in.)	8.25 m (27 ft. 1 in.)
G Height to Hinge Pin, Fully Raised	3.89 m (12 ft. 9 in.)	3.89 m (12 ft. 9 in.)	4.17 m (13 ft. 8 in.)	4.17 m (13 ft. 8 in.)	4.49 m (14 ft. 9 in.)	4.49 m (14 ft. 9 in.)
H Dump Clearance, 45 deg., Full Height	2.80 m (9 ft. 2 in.)	2.80 m (9 ft. 2 in.)	3.14 m (10 ft. 4 in.)	3.09 m (10 ft. 2 in.)	3.47 m (11 ft. 4 in.)	3.41 m (11 ft. 2 in.)
I Reach, 45-deg. Dump, Full Height	1.01 m (3 ft. 4 in.)	1.01 m (3 ft. 4 in.)	1.09 m (3 ft. 7 in.)	1.14 m (3 ft. 9 in.)	1.13 m (3 ft. 8 in.)	1.19 m (3 ft. 11 in.)
J Reach, 45-deg. Dump, 2.13-m (7 ft. 0 in.) Clearance	1.51 m (4 ft. 11 in.)	1.51 m (4 ft. 11 in.)	1.81 m (5 ft. 11 in.)	1.84 m (6 ft. 0 in.)	2.10 m (6 ft. 11 in.)	2.14 m (7 ft. 0 in.)
K Maximum Digging Depth	0.1 m (4 in.)	0.1 m (4 in.)	0.19 m (8 in.)	0.2 m (8 in.)	0.2 m (8 in.)	0.2 m (8 in.)
L Maximum Rollback at Ground Level	44 deg.	44 deg.	48 deg.	48 deg.	49 deg.	49 deg.
M Maximum Rollback, Boom Fully Raised	60 deg.	60 deg.	60 deg.	60 deg.	61 deg.	61 deg.
N Maximum Bucket Dump Angle, Fully Raised	48 deg.	48 deg.	46 deg.	46 deg.	45 deg.	45 deg.
Loader Clearance Circle, Bucket Carry Position	11.46 m (37 ft. 7 in.)	11.58 m (38 ft. 0 in.)	11.68 m (38 ft. 4 in.)	11.70 m (38 ft. 5 in.)	12.16 m (39 ft. 11 in.)	12.20 m (40 ft. 0 in.)
<b>Specifications With Bucket With Bolt-On Edge</b>						
Capacity, Heaped	2.3 m <sup>3</sup> (3.0 cu. yd.)	2.5 m <sup>3</sup> (3.25 cu. yd.)	2.1 m <sup>3</sup> (2.75 cu. yd.)	2.3 m <sup>3</sup> (3.0 cu. yd.)	2.1 m <sup>3</sup> (2.75 cu. yd.)	2.3 m <sup>3</sup> (3.0 cu. yd.)
Capacity, Struck	1.9 m <sup>3</sup> (2.5 cu. yd.)	2.1 m <sup>3</sup> (2.7 cu. yd.)	1.7 m <sup>3</sup> (2.3 cu. yd.)	1.9 m <sup>3</sup> (2.5 cu. yd.)	1.7 m <sup>3</sup> (2.3 cu. yd.)	1.9 m <sup>3</sup> (2.5 cu. yd.)
Bucket Weight With Bolt-On Cutting Edge	1095 kg (2,415 lb.)	1131 kg (2,493 lb.)	1056 kg (2,327 lb.)	1095 kg (2,415 lb.)	1056 kg (2,327 lb.)	1095 kg (2,415 lb.)
Bucket Width	2.54 m (8 ft. 4 in.)	2.68 m (8 ft. 10 in.)	2.55 m (8 ft. 4 in.)	2.54 m (8 ft. 4 in.)	2.55 m (8 ft. 4 in.)	2.54 m (8 ft. 4 in.)
Breakout Force	13 166 kg (29,026 lb.)	13 145 kg (28,979 lb.)	13 983 kg (30,827 lb.)	13 005 kg (28,672 lb.)	14 138 kg (31,168 lb.)	13 149 kg (28,988 lb.)
Tipping Load, Straight, No Tire Deflection	11 139 kg (24,557 lb.)	11 097 kg (24,464 lb.)	9699 kg (21,384 lb.)	9591 kg (21,145 lb.)	8630 kg (19,026 lb.)	8537 kg (18,820 lb.)
Tipping Load, Straight, With Tire Deflection	10 533 kg (23,221 lb.)	10 491 kg (23,129 lb.)	9231 kg (20,351 lb.)	9120 kg (20,106 lb.)	8244 kg (18,175 lb.)	8145 kg (17,957 lb.)
Tipping Load, 40-deg. Full Turn, No Tire Deflection	9653 kg (21,281 lb.)	9612 kg (21,190 lb.)	8374 kg (18,460 lb.)	8274 kg (18,241 lb.)	7410 kg (16,336 lb.)	7323 kg (16,145 lb.)
Tipping Load, 40-deg. Full Turn, With Tire Deflection	8865 kg (19,544 lb.)	8823 kg (19,451 lb.)	7755 kg (17,097 lb.)	7650 kg (16,865 lb.)	6891 kg (15,192 lb.)	6807 kg (15,007 lb.)
Rated Operating Load, 50% Full-Turn Tipping Load, No Tire Deflection (conforms to ISO 14397-1)*	4827 kg (10,641 lb.)	4806 kg (10,595 lb.)	4187 kg (9,230 lb.)	4137 kg (9,120 lb.)	3705 kg (8,168 lb.)	3662 kg (8,073 lb.)
Rated Operating Load, 50% Full-Turn Tipping Load, With Tire Deflection (conforms to ISO 14397-1)*	4433 kg (9,772 lb.)	4412 kg (9,726 lb.)	3878 kg (8,548 lb.)	3825 kg (8,433 lb.)	3446 kg (7,596 lb.)	3404 kg (7,503 lb.)
Operating Weight	13 844 kg (30,520 lb.)	13 879 kg (30,598 lb.)	13 992 kg (30,847 lb.)	14 032 kg (30,935 lb.)	14 178 kg (31,257 lb.)	14 218 kg (31,345 lb.)

Loader operating information is based on machine with identified linkage and standard equipment, PowerTech PVS 6068 (EPA Final Tier 4/EU Stage V) engine, ROPS cab, rear cast bumper/counterweight, transmission side-frame guards, bottom guards, standard tires, full fuel tank, and 79-kg (175 lb.) operator. This information is affected by changes in tires, ballast, and different attachments.

\*Rated operating capacity based on Deere attachments only.

While general information, pictures, and descriptions are provided, some illustrations and text may include product options and accessories NOT AVAILABLE in all regions, and in some countries products and accessories may require modifications or additions to ensure compliance with the local regulations of those countries.

# 544 P-TIER

## Dimensions and Specifications With Hi-Vis Coupler and Hook-On Construction Forks

## 544 P-TIER Z-BAR / HIGH-LIFT / HIGH-LIFT PLUS

## 544 P-TIER Z-BAR / HIGH-LIFT / HIGH-LIFT PLUS LOADERS WITH HI-VIS COUPLER AND HOOK-ON CONSTRUCTION FORKS

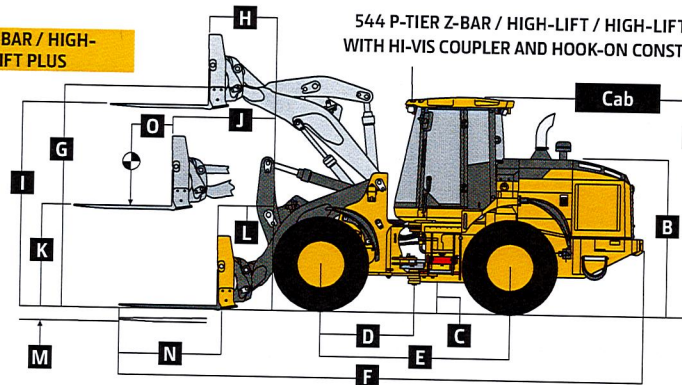

	Z-Bar 1.52-m (60 in.) tine length	Z-Bar 1.83-m (72 in.) tine length	High-Lift 1.52-m (60 in.) tine length	High-Lift 1.83-m (72 in.) tine length	High-Lift Plus 1.52-m (60 in.) tine length	High-Lift Plus 1.83-m (72 in.) tine length
<b>Dimensions With Forks</b> <i>(illustration above right)</i>						
<b>A</b> Height to Top of Cab	3.33 m (10 ft. 11 in.)	3.33 m (10 ft. 11 in.)	3.33 m (10 ft. 11 in.)	3.33 m (10 ft. 11 in.)	3.33 m (10 ft. 11 in.)	3.33 m (10 ft. 11 in.)
<b>B</b> Hood Height	2.375 m (7 ft. 9 in.)	2.375 m (7 ft. 9 in.)	2.375 m (7 ft. 9 in.)	2.375 m (7 ft. 9 in.)	2.375 m (7 ft. 9 in.)	2.375 m (7 ft. 9 in.)
<b>C</b> Ground Clearance	0.40 m (15.7 in.)	0.40 m (15.7 in.)	0.40 m (15.7 in.)	0.40 m (15.7 in.)	0.40 m (15.7 in.)	0.40 m (15.7 in.)
<b>D</b> Length From Centerline to Front Axle	1.45 m (4 ft. 9 in.)	1.45 m (4 ft. 9 in.)	1.45 m (4 ft. 9 in.)	1.45 m (4 ft. 9 in.)	1.45 m (4 ft. 9 in.)	1.45 m (4 ft. 9 in.)
<b>E</b> Wheelbase	2.93 m (9 ft. 7 in.)	2.93 m (9 ft. 7 in.)	2.93 m (9 ft. 7 in.)	2.93 m (9 ft. 7 in.)	2.93 m (9 ft. 7 in.)	2.93 m (9 ft. 7 in.)
<b>F</b> Overall Length, Forks on Ground	8.29 m (27 ft. 2 in.)	8.59 m (28 ft. 2 in.)	8.68 m (28 ft. 6 in.)	8.98 m (29 ft. 6 in.)	9.04 m (29 ft. 8 in.)	9.35 m (30 ft. 8 in.)
<b>G</b> Height to Hinge Pin, Fully Raised	3.89 m (12 ft. 9 in.)	3.89 m (12 ft. 9 in.)	4.17 m (13 ft. 8 in.)	4.17 m (13 ft. 8 in.)	4.49 m (14 ft. 9 in.)	4.49 m (14 ft. 9 in.)
<b>H</b> Reach, Fully Raised	0.80 m (31 in.)	0.80 m (31 in.)	0.92 m (3 ft. 0 in.)	0.92 m (3 ft. 0 in.)	0.97 m (3 ft. 2 in.)	0.97 m (3 ft. 2 in.)
<b>I</b> Fork Height, Fully Raised	3.56 m (11 ft. 8 in.)	3.56 m (11 ft. 8 in.)	3.84 m (12 ft. 7 in.)	3.84 m (12 ft. 7 in.)	4.16 m (13 ft. 8 in.)	4.16 m (13 ft. 8 in.)
<b>J</b> Maximum Reach, Fork Level	1.59 m (5 ft. 3 in.)	1.59 m (5 ft. 3 in.)	1.89 m (6 ft. 2 in.)	1.89 m (6 ft. 2 in.)	2.16 m (7 ft. 1 in.)	2.16 m (7 ft. 1 in.)
<b>K</b> Fork Height, Maximum Reach	1.66 m (5 ft. 5 in.)	1.66 m (5 ft. 5 in.)	1.66 m (5 ft. 5 in.)	1.66 m (5 ft. 5 in.)	1.66 m (5 ft. 5 in.)	1.66 m (5 ft. 5 in.)
<b>L</b> Reach, Ground Level	1.03 m (3 ft. 5 in.)	1.03 m (3 ft. 5 in.)	1.40 m (4 ft. 7 in.)	1.40 m (4 ft. 7 in.)	1.72 m (5 ft. 8 in.)	1.72 m (5 ft. 8 in.)
<b>M</b> Depth Below Ground	91 mm (4 in.)	91 mm (4 in.)	190 mm (7 in.)	190 mm (7 in.)	195 mm (8 in.)	195 mm (8 in.)
<b>N</b> Tine Length	1.52 m (60 in.)	1.83 m (72 in.)	1.52 m (60 in.)	1.83 m (72 in.)	1.52 m (60 in.)	1.83 m (72 in.)
<b>O</b> Load Position, 50% Tine Length	0.76 m (30 in.)	0.91 m (3 ft. 0 in.)	0.76 m (30 in.)	0.91 m (3 ft. 0 in.)	0.76 m (30 in.)	0.91 m (3 ft. 0 in.)
<b>Specifications With Forks</b>						
Tipping Load, Straight, No Tire Deflection	7263 kg (16,013 lb.)	6852 kg (15,107 lb.)	6480 kg (14,287 lb.)	6132 kg (13,520 lb.)	5909 kg (13,027 lb.)	5604 kg (12,355 lb.)
Tipping Load, Straight, With Tire Deflection	7068 kg (15,582 lb.)	6669 kg (14,703 lb.)	6309 kg (13,909 lb.)	5973 kg (13,168 lb.)	5751 kg (12,679 lb.)	5451 kg (12,017 lb.)
Tipping Load, 40-deg. Full Turn, No Tire Deflection	6261 kg (13,804 lb.)	5897 kg (13,001 lb.)	5556 kg (12,249 lb.)	5248 kg (11,569 lb.)	5033 kg (11,096 lb.)	4763 kg (10,501 lb.)
Tipping Load, 40-deg. Full Turn, With Tire Deflection	5991 kg (13,208 lb.)	5649 kg (12,454 lb.)	5319 kg (11,726 lb.)	5031 kg (11,091 lb.)	4830 kg (10,648 lb.)	4566 kg (10,066 lb.)
Rated Operating Load, 50% Full-Turn Tipping Load, With Tire Deflection (conforms to ISO 14397-1 and SAE J1197)*	2996 kg (6,604 lb.)	2825 kg (6,227 lb.)	2660 kg (5,863 lb.)	2516 kg (5,546 lb.)	2415 kg (5,324 lb.)	2283 kg (5,033 lb.)
Rated Operating Load, Rough Terrain, 60% Full-Turn Tipping Load, With Tire Deflection (conforms to EN474-3)*	3595 kg (7,925 lb.)	3389 kg (7,472 lb.)	3191 kg (7,036 lb.)	3019 kg (6,655 lb.)	2898 kg (6,389 lb.)	2740 kg (6,040 lb.)
Rated Operating Load, Firm and Level Ground, 80% Full-Turn Tipping Load, With Tire Deflection (conforms to EN474-3)*	4793 kg (10,566 lb.)	4519 kg (9,963 lb.)	4255 kg (9,381 lb.)	4025 kg (8,873 lb.)	3864 kg (8,519 lb.)	3653 kg (8,053 lb.)
Operating Weight	14 108 kg (31,103 lb.)	14 168 kg (31,236 lb.)	14 297 kg (31,520 lb.)	14 357 kg (31,652 lb.)	14 483 kg (31,930 lb.)	14 544 kg (32,063 lb.)

Loader operating information is based on machine with identified linkage and standard equipment, PowerTech PVS 6068 (EPA Final Tier 4/EU Stage V) engine, ROPS cab, rear cast bumper/counterweight, transmission side-frame guards, bottom guards, standard tires, full fuel tank, and 79-kg (175 lb.) operator. This information is affected by changes in tires, ballast, and different attachments. / \*Rated operating capacity based on Deere attachments only.

## Adjustments to Operating Weights and Tipping Loads With Buckets

Adjustments to operating weights, tipping loads, and tires are based on Z-Bar machine with pin-on 2.3-m<sup>3</sup> (3.0 cu. yd.) enhanced-performance bucket with bolt-on cutting edge, ROPS cab, rear cast bumper/counterweight, transmission side-frame guards, bottom guards, standard tires, full fuel tank, and 79-kg (175 lb.) operator\*

	Operating Weight	Tipping Load, Straight	Tipping Load, 40-deg. Full Turn	Tread Width	Width Over Tires	Vertical Height
Add (+) or deduct (-) kg (lb.) as indicated for loaders with 3-piece rims						
Michelin 20.5 R 25, 1 Star L-3 XHA2	0 kg (0 lb.)	0 kg (0 lb.)	0 kg (0 lb.)	0 mm (0 in.)	0 mm (0 in.)	0 mm (0 in.)
Bridgestone 20.5 R 25, 1 Star L-3 VJT	+4 kg (+9 lb.)	+3 kg (+6 lb.)	+7 kg (+14 lb.)	+2 mm (+0.1 in.)	+2 mm (+0.1 in.)	-41 mm (-1.6 in.)
Titan 20.5 R 25, 1 Star L-3 STL3	+11 kg (+23 lb.)	+7 kg (+16 lb.)	+7 kg (+14 lb.)	0 mm (0 in.)	-7 mm (-0.3 in.)	-5 mm (-0.2 in.)
Michelin 20.5 R 25, 1 Star L-2 XTLA	-152 kg (-335 lb.)	-107 kg (-235 lb.)	-94 kg (-207 lb.)	0 mm (0 in.)	+4 mm (+0.2 in.)	-11 mm (-0.4 in.)
Bridgestone 20.5 R 25, 1 Star L-2 VUT	-65 kg (-144 lb.)	-46 kg (-101 lb.)	-40 kg (-89 lb.)	0 mm (0 in.)	+3 mm (+0.1 in.)	-10 mm (-0.4 in.)
Titan 20.5 R 25, 1 Star L-2 TGD2	-85 kg (-188 lb.)	-60 kg (-132 lb.)	-53 kg (-116 lb.)	0 mm (0 in.)	-7 mm (-0.3 in.)	-10 mm (-0.4 in.)
Titan 20.5-25, 16 PR L-2	-245 kg (-541 lb.)	-172 kg (-379 lb.)	-152 kg (-335 lb.)	0 mm (0 in.)	+8 mm (+0.3 in.)	-2 mm (-0.1 in.)
Firestone 20.5-25, 16 PR L-2 SGG LD	-280 kg (-617 lb.)	-196 kg (-433 lb.)	-173 kg (-382 lb.)	0 mm (0 in.)	+5 mm (+0.2 in.)	-1 mm (0 in.)
Titan 20.5-25, 12 PR L-2	-266 kg (-587 lb.)	-187 kg (-412 lb.)	-165 kg (-363 lb.)	0 mm (0 in.)	+8 mm (+0.3 in.)	-2 mm (-0.1 in.)
Firestone 20.5-25, 16 PR L-3 SRG LD	-276 kg (-608 lb.)	-194 kg (-427 lb.)	-171 kg (-376 lb.)	0 mm (0 in.)	+8 mm (+0.3 in.)	+3 mm (+0.1 in.)
Michelin 20.5 R 25, 1 Star L2 SNO-PLUS	-96 kg (-212 lb.)	-67 kg (-148 lb.)	-59 kg (-131 lb.)	0 mm (0 in.)	+6 mm (+0.2 in.)	-16 mm (-0.6 in.)
Michelin 620/75R26 MegaXbib <sup>ES</sup>	-189 kg (-417 lb.)	-133 kg (-293 lb.)	-117 kg (-258 lb.)	+187 mm (+7.4 in.)	+247 mm (+9.7 in.)	+23 mm (+0.9 in.)
Michelin 750/65R26 MegaXbib <sup>ES</sup>	+55 kg (+121 lb.)	+38 kg (+85 lb.)	+34 kg (+75 lb.)	+322 mm (+12.7 in.)	+521 mm (+20.5 in.)	+36 mm (+1.4 in.)
CaCl <sub>2</sub> in 20.5-25, L-3 Rear Tires, 75% Fill	+825 kg (+1,820 lb.)	+1157 kg (+2,551 lb.)	+1020 kg (+2,250 lb.)	N/A	N/A	N/A

\*May change based on vehicle configuration, weight, or tire-pressure adjustments.

<sup>E</sup>Equipped with 1-piece rims.

<sup>B</sup>Requires 8-deg. rear axle stops.

# Additional equipment (cont.)

Key: ● Standard ▲ Optional or special  
See your John Deere dealer for further information.

## 544 P Steering Systems

- Conventional steering wheel with spinner knob
- ▲ Secondary steering
- Electrical**
- Solid-state electrical power-distribution system
- Lockable master electrical-disconnect switch
- Battery-terminal safety covers
- By-pass start safety cover at starter
- Remote jump-start access in battery box
- Pre-wired for beacon/strobe light
- Lights: Halogen driving lights with guards (2) / Front (4), rear cab (2), and rear grille (2) work lights / LED front turn signals and flashers / LED stop- and taillights
- ▲ Premium LED light package (all exterior lights are heavy-duty LED)
- Programmable courtesy lights
- Horn, electric
- Reverse warning alarm
- Multifunction/multi-language 178-mm (7 in.) LCD color monitor includes: Digital instruments — Analog display (hydraulic oil temperature, engine coolant temperature, transmission oil temperature, and engine oil pressure) / Digital display (engine rpm, transmission gear/direction indicator, hour meter, fuel level, diesel exhaust fluid (DEF) level, speedometer, odometer, and average fuel consumption)
- ▲ Multifunction/multi-language 127-mm (5 in.) LCD color monitor includes: Digital instruments — Analog display (hydraulic oil temperature, engine coolant temperature, transmission oil temperature, and engine oil pressure) / Digital display (engine rpm, transmission gear/direction indicator, hour meter, fuel level, DEF level, speedometer, odometer, and average fuel consumption)
- ▲ Integrated cycle counter with 5 categories
- Indicator lights: Standard and selected options / Amber caution and red stop
- Operator-warning messages
- Built-in diagnostics: Diagnostic-code details / Sensor values / Calibrations / Individual circuit tester
- ▲ Electrical corrosion-prevention package
- Standard AM/FM/Weather-Band (WB) radio with remote auxiliary port
- ▲ Premium AM/FM/WB radio with Bluetooth®, remote auxiliary port, and remote USB port (premium cab only)
- 24- to 12-volt, 8-amp converter and cab power ports (3)
- ▲ 24- to 12-volt, 15- or 30-amp converter and cab power ports (3)

## 544 P Operator's Station

- Standard cab with air conditioning/heater (ROPS/FOPS Level 1, isolation mounted)
- ▲ Premium cab with air conditioning/heater (ROPS/FOPS Level 1, isolation mounted)
- ▲ Automatic temperature control (premium cab only)
- Rear window defrost vent
- Keyless start with multiple security modes
- Sealed-switch module with function indicators
- Seat with backrest extension, deep foam, fabric cover, and adjustable air suspension
- ▲ Premium seat with high-wide back- and headrest extension, heated and ventilated, leather/fabric cover, and adjustable heavy-duty air suspension
- Hydraulic controls integrated to seat
- High-visibility, bright-orange seat belt, 76 mm (3 in.), with retractor
- ▲ 4-point seat-belt harness
- ▲ Seat-belt minder monitoring with JDLink™ and seat-belt indicator beacon
- Cup holder and cup/Thermos® holder with retaining strap
- Lunch-box/cooler holder with tie-down brackets
- Coat hook
- LED dome and reading light
- Rubber floor mat
- Dual-tilt steering column
- Operator's manual storage compartment
- Outside (2) and inside (1) rearview mirrors
- ▲ Heated outside mirrors with convex lens
- ▲ In-cab adjustable heated outside mirrors with convex lens (premium cab only)
- Left-side operator-station access
- Fall-arrest system anchor points tested to 2268 kg (5,000 lb.) on front of cab
- Slip-resistant steps and ergonomic handholds
- Pull-down front sun visor
- Front and rear intermittent windshield wipers and washers
- ▲ Powered cab air pre-cleaner
- ▲ Beacon bracket only
- ▲ Beacon bracket with strobe beacon
- Rearview camera
- ▲ Rearview camera with radar object-detection system
- ▲ Dedicated 178-mm (7 in.) rear camera display
- ▲ Advanced Rear Object-Detection System
- ▲ Advanced Vision System
- Payload scale ready
- ▲ SmartWeigh™ ready + trial
- ▲ SmartWeigh
- ▲ SmartDetect™
- ▲ Fire extinguisher

## 544 P Loader Linkage

- Z-Bar loader linkage (parallel lift)
- ▲ High-Lift Z-Bar loader linkage (parallel lift)
- ▲ High-Lift Plus Z-Bar loader linkage (parallel lift)
- Buckets and Attachments**
- ▲ Full line of Deere pin-on buckets, coupler buckets, and forks
- ▲ John Deere hydraulic coupler that accepts JRB-pattern attachments
- ▲ Hi-Vis hydraulic coupler that accepts Euro-pattern attachments (ISO)
- Overall Vehicle**
- JDLink wireless communication system (available in specific countries; see your dealer for details)
- NeverGrease™ rear-axle oscillation
- Front and rear tie-downs
- Rear cast bumper/counterweight with rear hitch and locking pin
- Articulation locking bar
- Loader boom service locking bar
- 40-deg. steering articulation to each side with rubber-cushion stops on frame
- Vandal protection with lockable engine enclosures, right counterweight storage, and filler access for radiator/fuel/DEF/hydraulic transmission
- Left-side service steps and handholds
- ▲ Right-side service steps and handrails
- ▲ Left-side close-mounted steps
- Storage compartment
- Fuel-tank fill strainer
- Heavy-duty fuel-tank guard
- Ground-level fuel and DEF fill
- Same-side ground-level daily servicing
- 20.5R25 tires on 3-piece rims
- ▲ Ag material-handling package
- ▲ Environmental drains and sample ports for engine, transmission, hydraulic oils, and engine coolant
- Fenders, front narrow
- ▲ Fenders, front full width
- ▲ Fenders, front and rear full width
- ▲ Fenders, front and rear full width with mud flaps
- ▲ Less wheels and tires with axle stops
- ▲ Rims less tires
- ▲ Transmission side-frame and bottom guards
- ▲ Lift eyes
- ▲ License-plate bracket and light

While general information, pictures, and descriptions are provided, some illustrations and text may include product options and accessories NOT AVAILABLE in all regions, and in some countries products and accessories may require modifications or additions to ensure compliance with the local regulations of those countries.

Net engine power is with standard equipment including air cleaner, exhaust system, alternator, and cooling fan at test conditions per ISO 9249. No derating is required up to 3050-m (10,000 ft.) altitude. Specifications and design subject to change without notice. Specifications with the exception of bucket capacity are in accordance with all applicable ISO standards. Except where otherwise noted, these specifications are based on a unit with applicable linkage and standard equipment, ROPS cab, rear cast bumper/counterweight, transmission side-frame guards, bottom guards, standard tires, full fuel tank, and 79-kg (175 lb.) operator.